

APN: ____ - ____ - ____

MADERA COUNTY PLOT PLAN

Permit Number:

Plot Plan instructions are on back of application form.

Scale _____ = _____

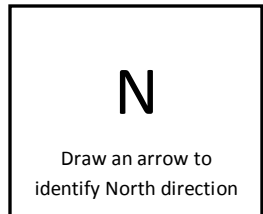

By signing this document, I declare that the foregoing and attached information forms are true and correct to the best of my knowledge.

Signature _____

Printed Name _____

Date _____

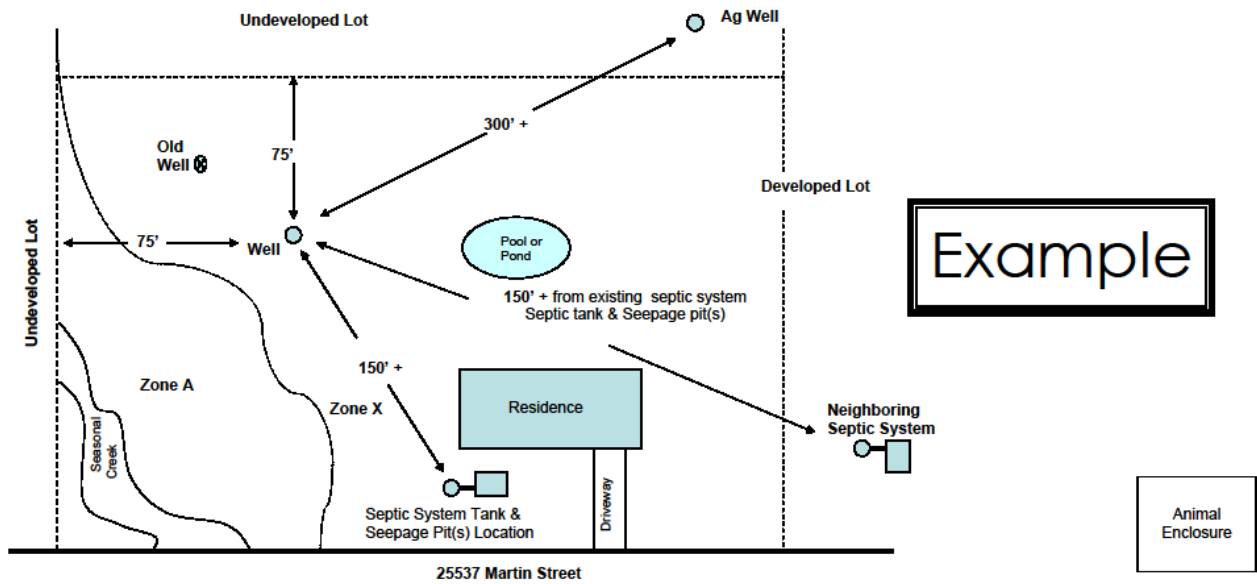

I declare under penalty of perjury under the laws of the State of California that the foregoing and attached information forms are true and correct.

Signature [Signature] Print Name John Redpath Date: 2/26/09

↑
N (indicate North direction by drawing arrow)
Scale: ~ 1 in = 50 ft

MCC 13.52.050(B) Well Standards.

Well Location. All well(s) shall be constructed to prevent the entrance of surface water and contaminated groundwater into the well or into the producing aquifer, and shall be separated a safe distance from potential sources of contamination and pollution. The following minimum horizontal distances shall be maintained for all wells furnishing potable water for human consumption:

(Distances in feet)	Agricultural Well	Domestic Well	Public Well*
Agricultural Wells		300	300
Areas of intense animal confinement	100	100	100
Leach line or disposal field	150	100	150
Seepage pit or cesspool	150	150	150
Septic tank	150	100	150
Sewer line	50	50	50

*The above separation distances are for wells with adequate annular seals drilled in dry upper consolidated formations that are less permeable than sand. Wells drilled in fractured rock formations need to have much greater separation distances.