

V:\CAD Files\W Dwg\W8-Air Vacuum & Release Valve.DWG 10-17-11 11:12:04 AM eii.mcfarland

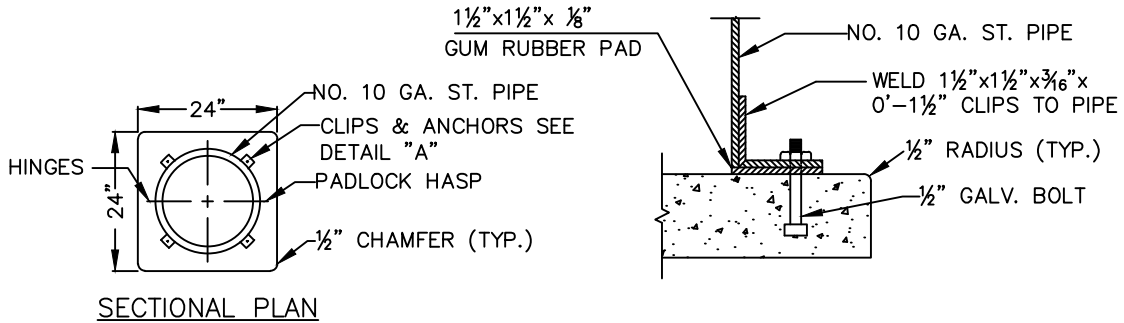
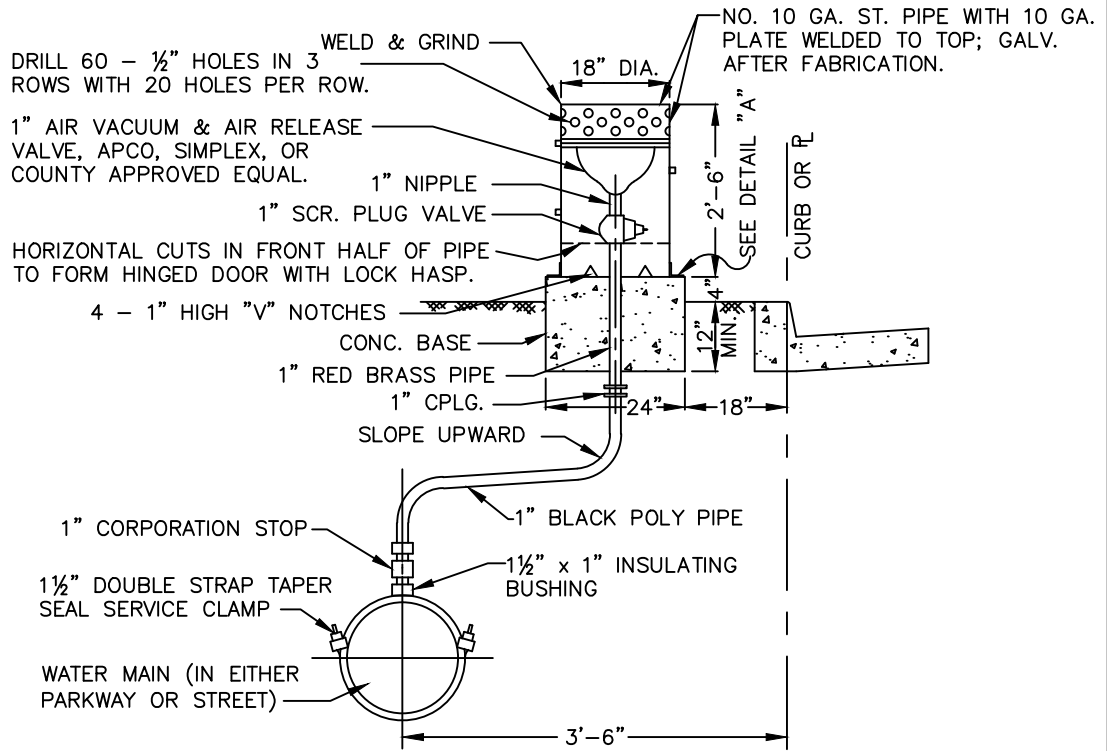

Spec's By _____	<b>COUNTY OF MADERA</b> <b>AIR VACUUM &amp; AIR RELEASE VALVE ASSEMBLY</b>	Date: 7-1-81
Drawn By <u>J. SHIELDS</u>		Scale: NONE
APPROVED BY _____		Drawing No. W-8
REVISIONS	8/1/02	4/22/2011