

V:\CAD Files\W Dwg\W5-Sewer Crossing,DWG 10-17-11 11:11:20 AM eli.mcfarland

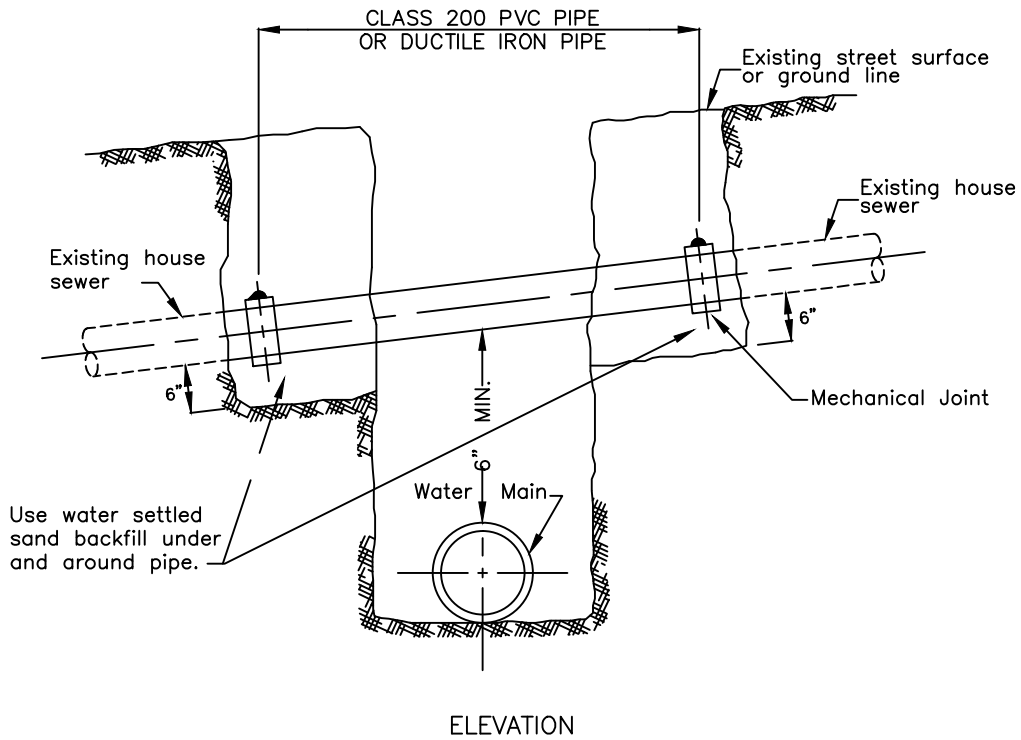
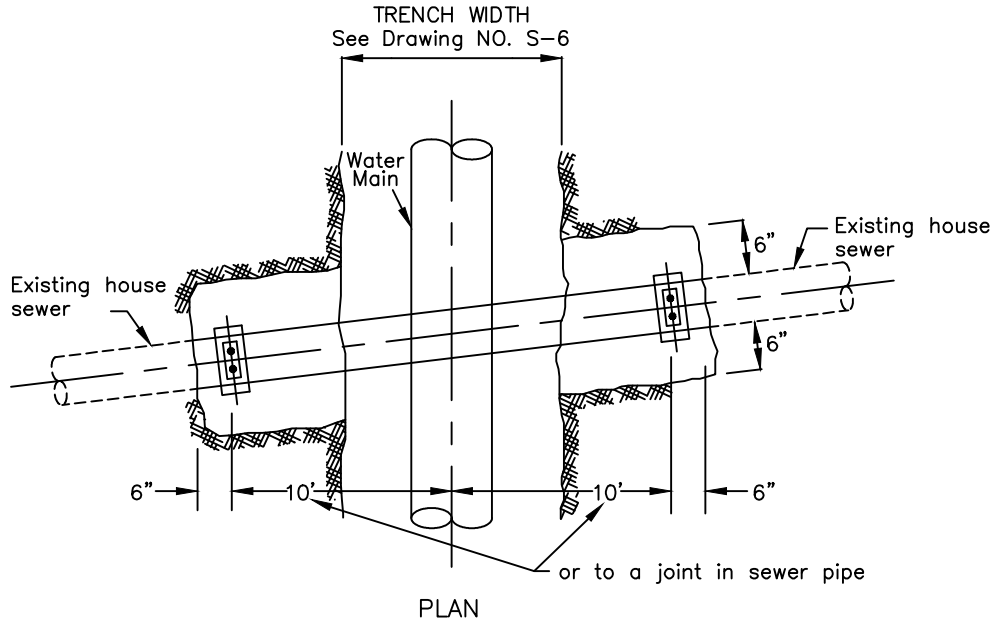

Spec's By _____

Drawn By J. SHIELDS

APPROVED BY _____

COUNTY OF MADERA

**REPLACEMENT OF HOUSE
SEWER CROSSING
WATER MAIN**

Date:
7-1-81

Scale:
NONE

Drawing No.
W-5

REVISIONS	8/1/02	4/22/2011				
-----------	--------	-----------	--	--	--	--