



# Community and Economic Development Planning Division

Jamie Bax  
Deputy Director

- 200 W. 4<sup>th</sup> Street
- Suite 3100
- Madera, CA 93637
- (559) 675-7821
- FAX (559) 675-6573
- TDD (559) 675-8970
- mc\_planning@madera-county.com

**PLANNING COMMISSION DATE:** August 6, 2019

**AGENDA ITEM:** # 4

<b>CUP</b>	<b>#2019-008</b>	<b>Conditional Use Permit for dairy digester facility</b>
<b>APN</b>	<b>#043-101-002, 043-096-005</b>	<b>Applicant/Owner: Diepersloot, Robert</b>
<b>CEQA</b>	<b>MND #2019-11</b>	<b>Mitigated Negative Declaration</b>

**REQUEST:**

The applicant is requesting to amend Conditional Use Permit #2014-014 to allow for a dairy digester facility that will feed biogas into a collection system generating electricity to power grid.

**LOCATION:**

The subject property is located on the north east and south west corner of Avenue 13 and Road 14, approximately 1.47 miles west of its' intersection with Road 16 (13668 Avenue 13), Madera

**ENVIRONMENTAL ASSESSMENT:**

A Mitigated Negative Declaration (MND #2019-11) (Exhibit N) has been prepared and is subject to approval by the Planning Commission.

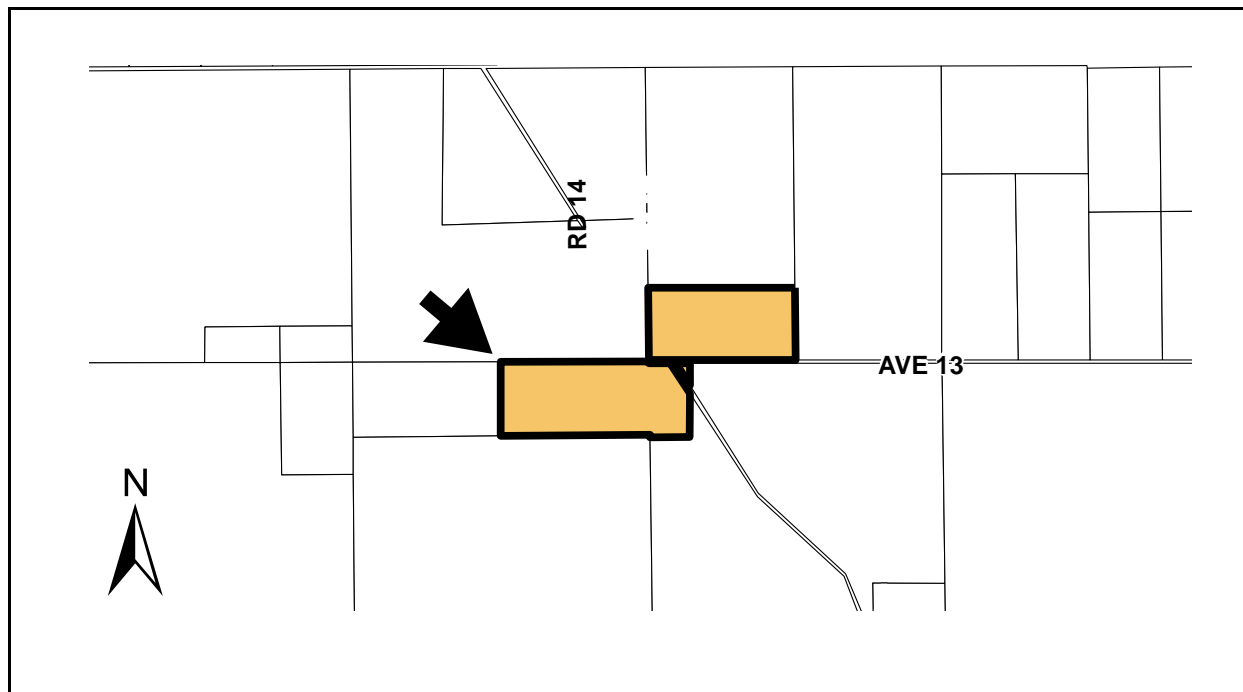

**RECOMMENDATION:** Staff recommends approval of Conditional Use Permit CUP#2019-008, Mitigated Negative Declaration #2019-11 and associated Mitigation Monitoring Program.

**GENERAL PLAN DESIGNATION (Exhibit A):**

**SITE:** AE (Agricultural Exclusive) Designation

**SURROUNDING:** AE (Agricultural Exclusive) Designation; OS (Open Space) Designation

**ZONING (Exhibit B):**

**SITE:** ARE-40 (Agricultural, Rural, Exclusive – 20 Acre) District

**SURROUNDING:** ARE-40 (Agricultural, Rural, Exclusive – 20 Acre) District; OS (Open Space)

**LAND USE:**

**SITE:** Dairy

**SURROUNDING:** Dairy, agriculture

**SIZE OF PROPERTY:** 178.98 Acres

**ACCESS (Exhibit A):** Access to the site is via Avenue 13

**BACKGROUND AND PRIOR ACTIONS:**

Conditional Use Permit #97-01 was approved on April 1, 1997 to establish a new dairy with 2,880 milk cows and 1,600 support stock.

Conditional Use Permit #2014-014 was approved on February 3, 2015 allow for the construction of a freestall barn, expand an existing freestall barn, build a hospital barn, develop an area for raising calves in hutches, convert existing heifer pen to weaning pens for small heifers, build a commodity barn and a hay barn, and to construct a silage pad storage area. The dairy will increase to 7,500 milking cows, 1,500 dry cows, 8,200 heifers, and 1,800 calves. The operations are also adding five additional parcels associated with the dairy feed crops associated with the operations.

**PROJECT DESCRIPTION:**

This is a request to amend CUP #2014-014 to allow the construction and operation of an anaerobic digester at South Point Dairy, an existing dairy facility, along with necessary infrastructure for wastewater management. Additionally, it is proposed to construct a low-pressure pipeline to deliver biogas to a proposed Bloom Fuel Cell Energy Server (separate CUP) to be constructed 1 ½ miles northwest along Avenue 14.

**ORDINANCES/POLICIES:**

Chapter 18.58 of the Madera County Zoning Ordinance outlines the permitted uses within the ARE-40 (Agricultural, Rural, Exclusive – 40 Acre) District.

Chapter 18.92 of the Madera County Zoning Ordinance outlines the procedures for the processing and approval of conditional use permits.

Part 1 of the Madera County General Plan outlines the AE (Agricultural Exclusive) designation.

Madera County Dairy Standards outlines processes related to new and expanding dairies.

**ANALYSIS:**

The applicant is requesting to amend CUP #2014-014 to allow the construction and operation of an anaerobic digester at South Point Dairy, an existing dairy facility, along with necessary infrastructure for wastewater management. Additionally, it is proposed to construct a low-pressure pipeline to deliver biogas to a proposed Bloom Fuel Cell Energy Server (separate CUP) to be constructed 1.5 miles northwest along Avenue 14.

This is one of three dairies, all owned by the same operator, that are combining forces to produce biogas that will eventually be collected at one facility, generated in to electricity, and then sold to the utility grid. Biogas typically refers to a gas produced by the biological breakdown of organic matter in the absence of oxygen. Organic waste such as dead plant and animal material, animal feces, and kitchen waste can be converted to a gaseous fuel called biogas. Each dairy that is a part of the process will be connected via a low-pressure pipeline that will go along Road 14 to Avenue 14 and eventually to the collecting point at one of the dairies. The pipeline will be buried approximately 36" (thirty-six inches) beneath the surface leading to the bloom fuel energy server.

An anaerobic digester refers to an airtight vessel where anaerobic bacteria (those that thrive in the absence of oxygen) are used to digest (decompose or breakdown) an organic, carbon based, solid waste slurry, such as cow manure or food wastes, into smaller molecular weight compounds with lower residual odor. The anaerobic bacteria generate both methane ( $CH_4$ , also called nature gas) and carbon dioxide ( $CO_2$ ) gases in near equal volume as they digest the waste material. In modern anaerobic digesters, this biogas is captured and is used for energy recovery, typically in an internal combustion engine coupled to an electric generator. During the subsequent combustion, the methane is converted to carbon dioxide, releasing energy to drive the engine or provide heat for other uses. The process is widely used as a source of renewable energy.

The anaerobic digester will capture methane from decomposing manure sourced from the dairy facility and then converted to electricity which will be sold to an off-site electrical provider. Anaerobic digestion is a process by which microorganisms break down biodegradable material in the absence of oxygen. The process is a three step procedure. First is the decomposition of plant or animal matter, this step breaks down the organic material to usable sized molecules such as sugar. The second step is the conversion of decomposed matter to organic acids. Lastly, those acids are converted to methane gas. The biogas generated from the site will eventually be turned in to electricity which will then be sold to the power grid.

In 2003, the US consumed 147 trillion BTU (British Thermal Units – a unit of measure of the amount of energy required to heat one pound of water by one degree Fahrenheit) of energy from landfill gas, which equated to 0.6% of the total US natural gas consumption. When biogas is used, many advantages arise. As an example, in the US, utilization of biogas could generate enough electricity to meet up to three percent of the electrical expenditures.

As an example of this type of system, a hog farm in Tulare, hog manure is slurried and sent to a Hypalon-covered lagoon for biogas generation. The collected biogas fuels a 70 kilowatt engine-generator and a 100 kilowatt engine-generator. The electricity generated on the farm is able to meet monthly electric and heat energy demand.

The subject parcel is located within a rural, agricultural area where the majority of parcels range from approximately 40 acres to more than 600 acres in size.

Access will be via Avenue 14, approximately 1.47 miles west of its intersection with Road 16. The closest traffic counts done by the Madera County Transportation Commission (MCTC) in 2017 centers around Avenue 14 at its intersection with Road 16, which is approximately 1.47 miles west of the project site. Per the MCTC, there were 689 east bound and 739 west bound trips on Avenue 14, east of Road 16. There will be a minor increase of traffic in the area for the duration of construction of the site.

The project was circulated to County Departments and outside regulatory agencies for comments and conditions. This included the San Joaquin Valley Air Pollution Control District, Regional Water Quality Control, Department of Fish and Wildlife, the Chowchilla Yokuts Tribe, Picayune Rancheria of Chukchansi, Table Mountain Rancheria, and the Duma Tribe.

The Table Mountain Rancheria Tribe responded after the timeline requesting that if a records search had been conducted, and if so to provide a copy. Upon contacting the responding individual, the discussion centered on whether there was going to be any ground disturbance. Staff advised the individual that while yes there was going to be some by nature of the proposal, the work was being done on facility sites that have had development (dairy facilities) on them since at least the mid 1990's, as well as along the roadway which has been in place for even a longer period of time. The individual then indicated that they would bring this up with their supervisor and discuss whether consultation was further needed. Follow-up discussions with the Tribe indicated that they took the relevant information in to consideration and now consider the project as a non-issue given that the areas of construction were previously disturbed.

If this project is approved, the applicant will need to submit a check, made out to the County of Madera, in the amount of \$2,404.75 to cover the Notice of Determination (CEQA) filing at the Madera County Clerks' office. The amount covers the \$2,354.75 Department of Fish and Wildlife fee that took effect January 1, 2019 and the County Clerk \$50.00 filing fee. In lieu of the Fish and Wildlife fee, the applicant may choose to contact the Fresno office of the Department of Fish and Wildlife to apply for a fee waiver. The County Clerk Fee, Department of Fish and Wildlife Fee (or waiver if approved) is due within five days of approval of this permit at the Board of Supervisors.

**FINDINGS OF FACT:**

The following findings of fact must be made by the Planning Commission to make a finding of approval of the project. Should the Planning Commission vote to approve the project, Staff recommends that the Planning Commission concur with the following in light of the proposed conditions of approval.

1. *The proposed project does not violate the spirit or intent of the Zoning Ordinance.* The parcel is zoned ARE-40 (Agricultural, Rural, Exclusive – 40 Acre District). The zone designation allows for dairies with approved Conditional Use Permits. While typically digesters may be considered incidental to the dairy itself, it is the nature of the project itself that requires the amendment of the originating Conditional Use Permit.
2. *The proposed project is not contrary to the public health, safety, or general welfare.* The facility is located in a predominately agricultural portion of the County where dairies such as this are found. The digester facility being proposed would actually assist the overall air quality of the region by reducing methane production release typically found on dairies.

3. *The proposed project is not hazardous, harmful, noxious, offensive, or a nuisance because of noise, dust, smoke, odor, glare, or similar, factors, in that the project must adhere to the conditions of approval as well as mitigation measures. By its' nature, the project will not generate hazardous, harmful, noxious or offensive odors. In all, the digester will even reduce greenhouse gas production and assist in the creation of electricity.*
4. *The proposed project will not for any reason cause a substantial, adverse effect upon the property values and general desirability of the surrounding properties. The project as designed will not have an adverse effect upon the property values and general desirability of the surrounding properties.*

**WILLIAMSON ACT:**

The property is subject to a Williamson Act Contract. While the project site is on Williamson Act Contract property, due to the nature of the digester, and the fact that digesters are common facilities on dairies, this will not impact the Williamson Act Contract.

**GENERAL PLAN CONSISTENCY:**

The General Plan designation and the Area Plan designation for the parcels is AE (Agricultural Exclusive) Designation which allows for agricultural and residential uses by right. The property is zoned ARE-40 (Agricultural, Rural, Exclusive – 40 Acre) District which allows for agricultural and residential uses, as well as dairies with a conditional use permit. The General Plan and Zoning designations are consistent and compatible with each other.

**RECOMMENDATION:**

The analysis provided in this report supports approval of Conditional Use Permit (CUP #2019-008), Mitigated Negative Declaration (MND #2019-11) and Mitigation Monitoring Plan.

**CONDITIONS**

See attached.

**ATTACHMENTS:**

1. Exhibit A, General Plan Map
2. Exhibit B, Zoning Map
3. Exhibit C, Assessor's Map
4. Exhibit D, Site Plan
5. Exhibit D-1a, Conditioning Pad Plot Plan
6. Exhibit D-1b, Conditioning Pad Elevations
7. Exhibit D-1c, Conditioning Pad Foundation Plan
8. Exhibit D-2, Pipeline overview
9. Exhibit D-3, Pipeline Exhibit 1

**CUP #2019-008**  
**STAFF REPORT**

**August 6, 2019**

10. Exhibit D-4, Pipeline Exhibit 2
11. Exhibit E, Aerial Map
12. Exhibit F, Topographical Map
13. Exhibit G, Operational Statement
14. Exhibit H, Environmental Health Comments
15. Exhibit I, Fire Marshall's Office
16. Exhibit J, Air District Comments
17. Exhibit K, Water Board Comments
18. Exhibit L, Table Mountain Rancheria Comments
19. Exhibit M, Initial Study
20. Exhibit N, Mitigated Negative Declaration

## CONDITIONS OF APPROVAL

**PROJECT NAME:** CUP #2019-008 - South Point Dairy

**PROJECT LOCATION:** on the north side of Avenue 13, approximately 1.47 miles west of its intersection with Road 16 (14495 Avenue 13) Madera

**PROJECT DESCRIPTION:** Amending Conditional Use Permit to allow for dairy digester for sale of electricity to power grid

**APPLICANT:** Adrian Diepersloot

**CONTACT PERSON/TELEPHONE NUMBER:** 559-906-1935

No.	Condition	Department/Agency	Verification of Compliance		
			Initials	Date	Remarks
<b>Environmental Health</b>					
1	The facility must comply with their Report of Waste Discharge (RWD) requirements under the Regional Water Quality Control Board (RWQCB)				
2	The facility must comply with their San Joaquin Valley Air Pollution Control Board (SJVAPCCD) permits				
3	The facility must comply with Cal Recycle permit requirements for an Anaerobic Digester				
4	Provide/update Pest (vector) Management Plan. The Pest (vector) Management Plan must go into detail of how each known vector will be identified, tracked, eliminated or significantly reduced and how this program will be implemented. This Pest Management Plan must be provided for review and approval by this department prior to approving of this CUP to ensure that vector(s) are being handled on site to effectively prevent them or at a minimum significantly reduce them from becoming an off-site nuisance.				
5	Provide/Update Odor and Dust Management Plans. The Management Plans must go into detail in describing how odor and dust control will be managed and implemented. The Odor and Dust Management Plans must be provided for review and approval by this department prior to approval of this CUP to ensure that each known dairy nuisance(s) are handled on site to effectively prevent them from moving off-site creating a nuisance.				
6	If your facility handles/stores any hazardous materials on-site or generates hazardous waste you may be subject to permitting requirements through our department. As of January 2013, all Certified Unified Program Agency (CUPA) regulated businesses must submit their Hazardous Material Business Plans electronically into the California Environmental Reporting System (CERS) at <a href="http://www.cers.ca.gov">www.cers.ca.gov</a> .				







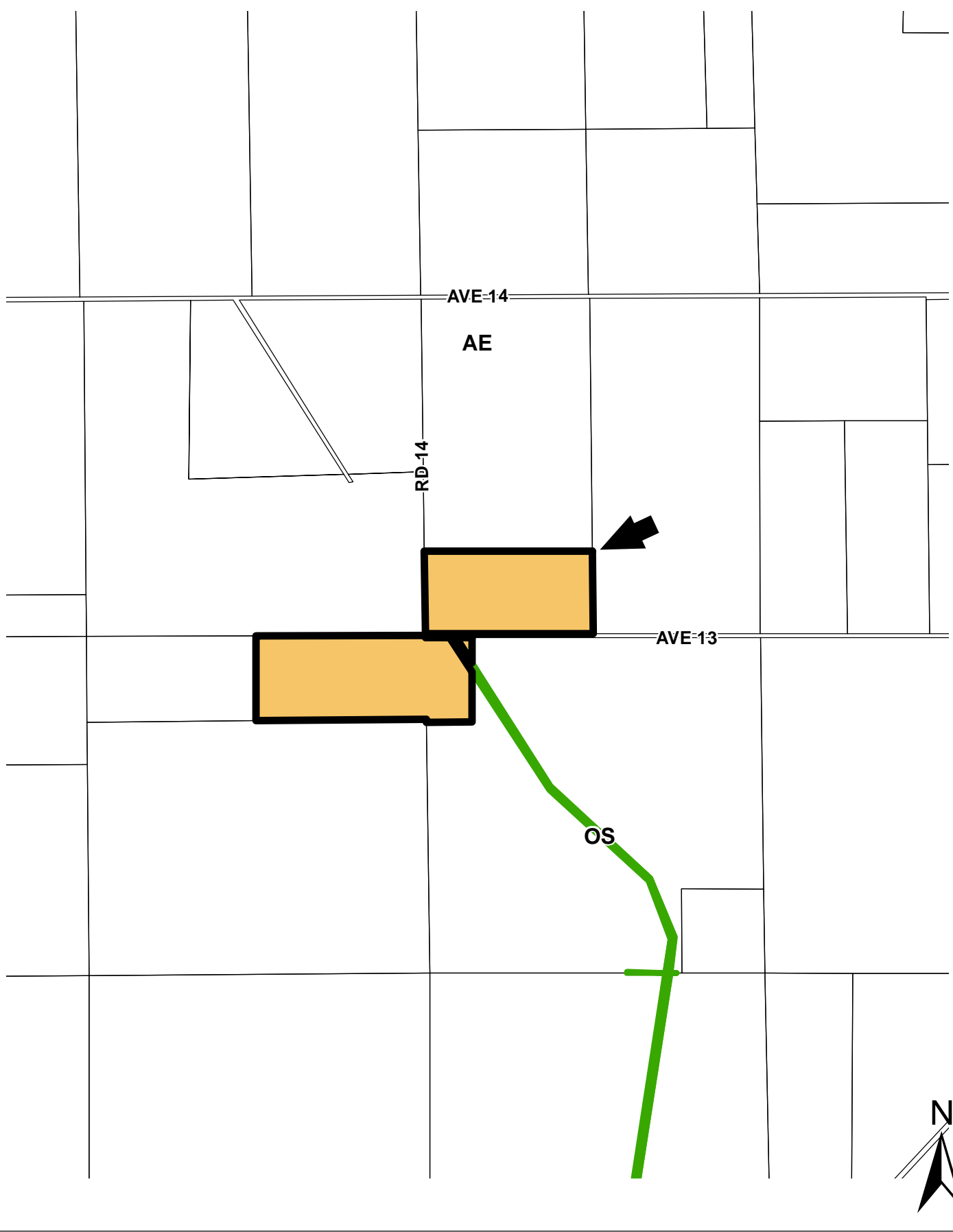

**GENERAL PLAN MAP**





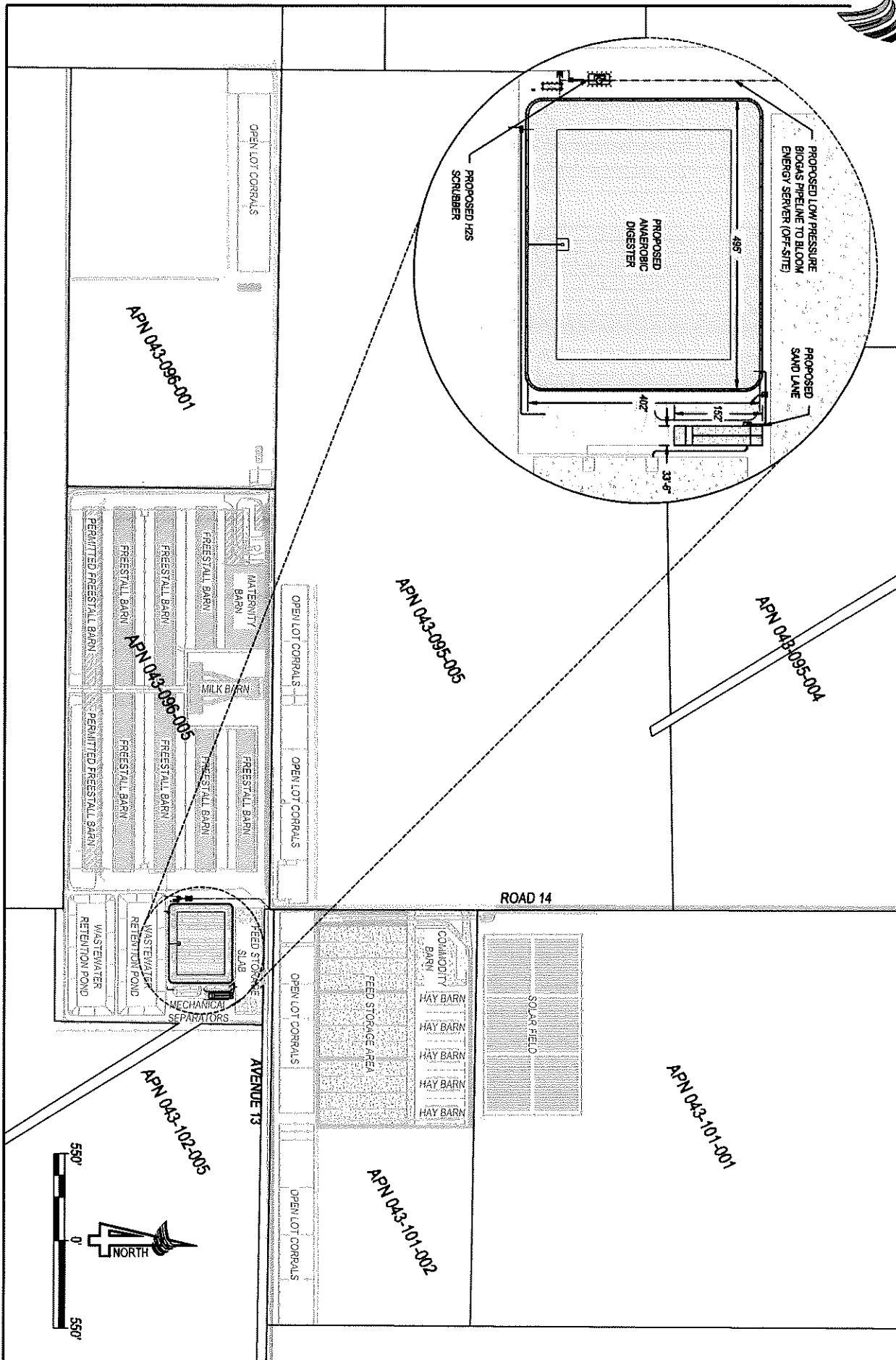



 324 S. Santa Fe, Ste. A  
 Visalia, CA 93292  
 (559) 882-3862  
 www.4-creeks.com

**SOUTH POINT DAIRY**  
**ANAEROBIC DIGESTER SITE PLAN**  
 MADERA COUNTY, CA

JOB NO. - SP
PLOT PLAN
3/18/2019
SCALE AS SHOWN

SITE PLAN

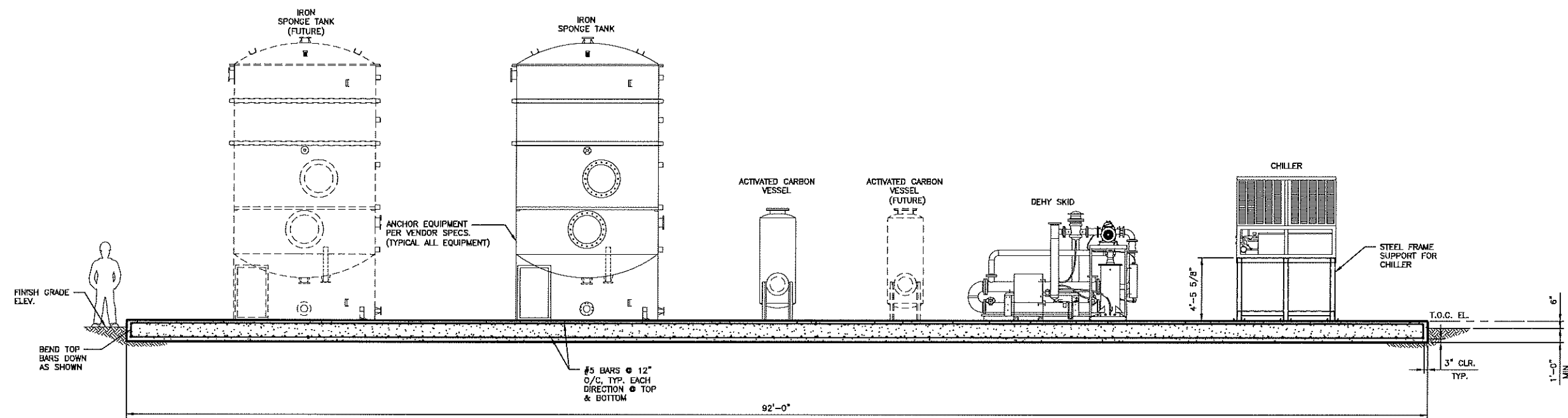



CONDITIONING PAD ELEVATIONS



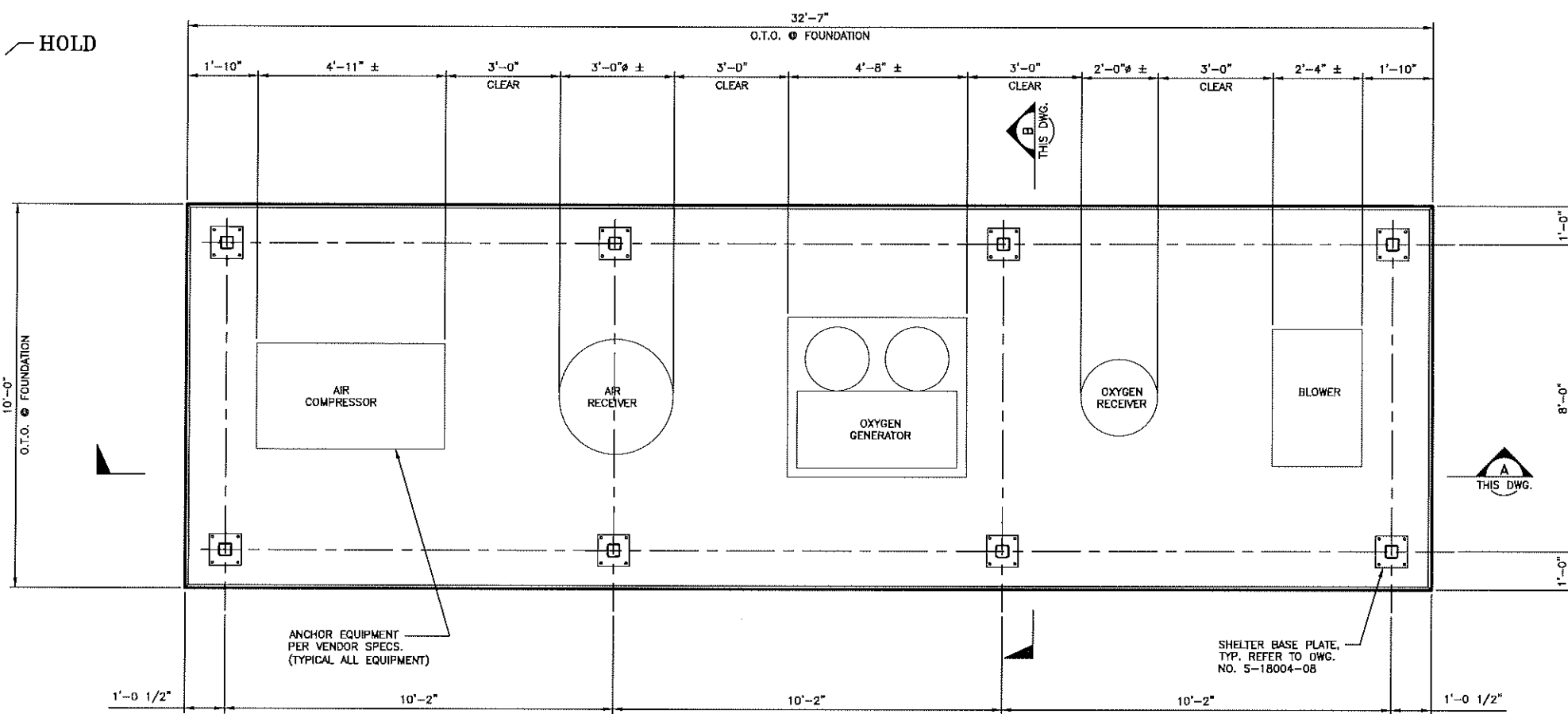

**FOUNDATION PLAN**  
SCALE: 1/2"=1'-0"

- NOTES:**
1. ALL MATERIAL SHALL COMPLY WITH THE 2016 CALIFORNIA BUILDING CODE.
  2. ALL FOUNDATIONS SHALL BEAR ON FIRM SOIL. SOIL MAY BE UNOBTURBED NATURAL GRADE OR CERTIFIED COMPACTED FILL.
  3. THE GRADE AROUND THE FOUNDATION SHALL SLOPE AWAY TO ALLOW FOR THE DRAINAGE AWAY FROM THE FOUNDATION. (MIN. 2% SLOPE, FOR 5 FT.)
  4. THIS PLAN IS FOR THE STRUCTURAL DESIGN OF THE FOUNDATION ONLY. ALL PORTIONS NOT SPECIFICALLY DETAILED SHALL BE BY OTHERS.
  5. THE CONTRACTOR SHALL HAVE THE SOLE RESPONSIBILITY FOR SAFETY AND GENERAL CONFORMANCE (OSHA, STATE & LOCAL SAFETY REGULATIONS.)
  6. THE CONTRACTOR SHALL LOCATE ALL EXISTING PIPELINES, CONDUIT, UTILITIES, POWERLINES, ETC. NEAR AND AROUND THE PROJECT SITE.
  7. THE CONTRACTOR SHALL VERIFY THE FOLLOWING PRIOR TO START OF CONSTRUCTION:
    - A. FOUNDATION LOCATION, ORIENTATION AND T.O.C. ELEVATION.
    - B. EQUIPMENT LOCATION AND ANCHORAGE.
    - C. NOZZLE CLEARANCES AND TIE-IN LOCATIONS.
  8. CONTRACTOR SHALL REFER TO ELECTRICAL PLANS FOR SIZE, LOCATION AND NUMBER OF REQUIRED CONDUIT PENETRATIONS. (SEE NOTE NO. 9 BELOW).
  9. CONTRACTOR SHALL ESTABLISH LAYOUT OF STUB-OUT LOCATIONS WITH THE ELECTRICAL CONDUIT ROUTING PLANS. CONDUIT PENETRATIONS AND PVC STUB-OUTS SHALL BE LOCATED, PLACED AND POSITIVELY SECURED PRIOR TO PLACEMENT OF CONCRETE.
  10. THE EQUIPMENT SHOWN IS FOR REFERENCE ONLY.

**PRELIMINARY  
NOT FOR CONSTRUCTION**

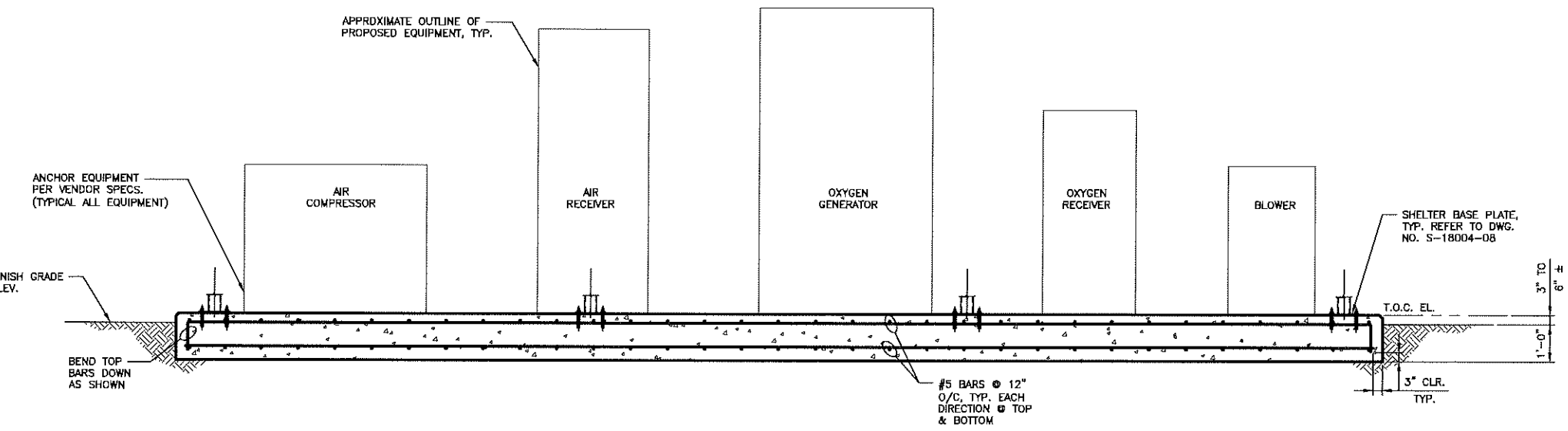

**SECTION A**  
SCALE: 1/2"=1'-0"  
LONGITUDINAL SECTION

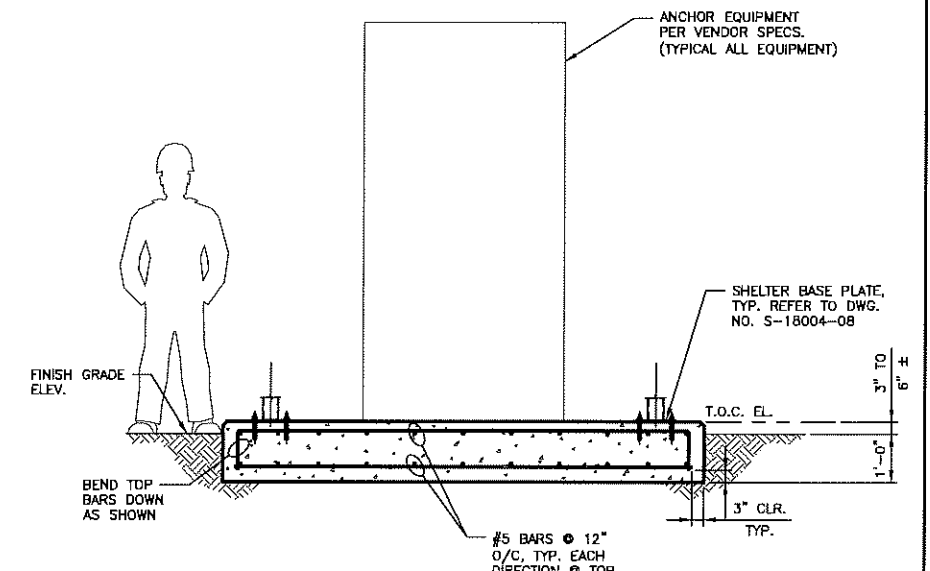

**SECTION B**  
SCALE: 1/2"=1'-0"  
TRANSVERSE SECTION



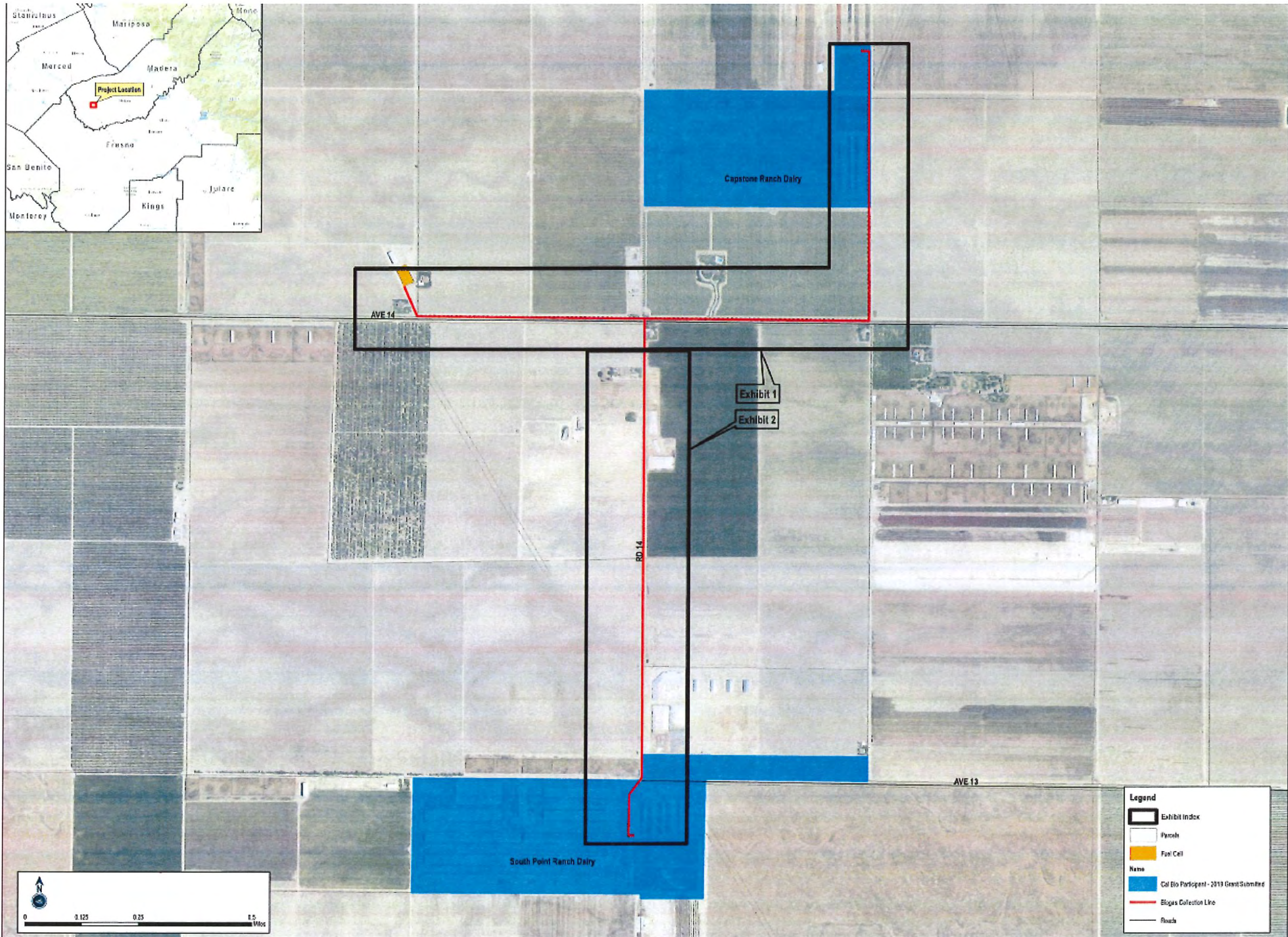

PIPELINE OVERVIEW



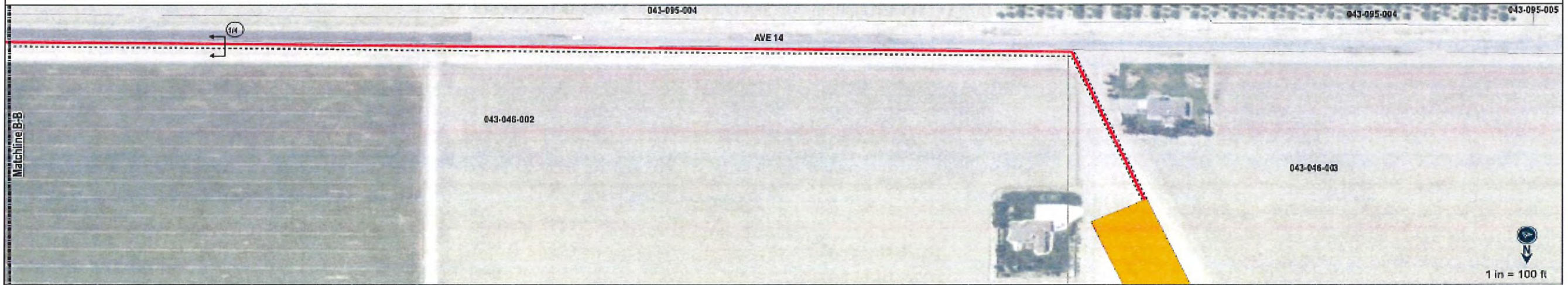
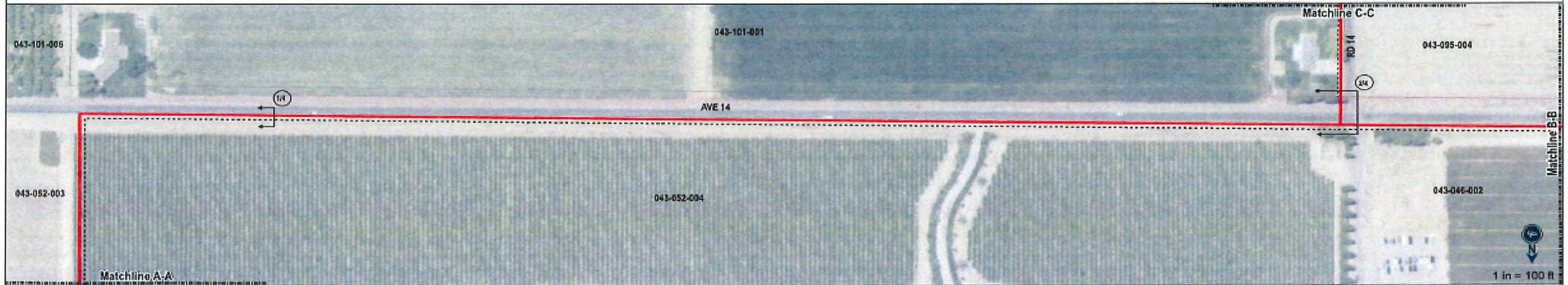
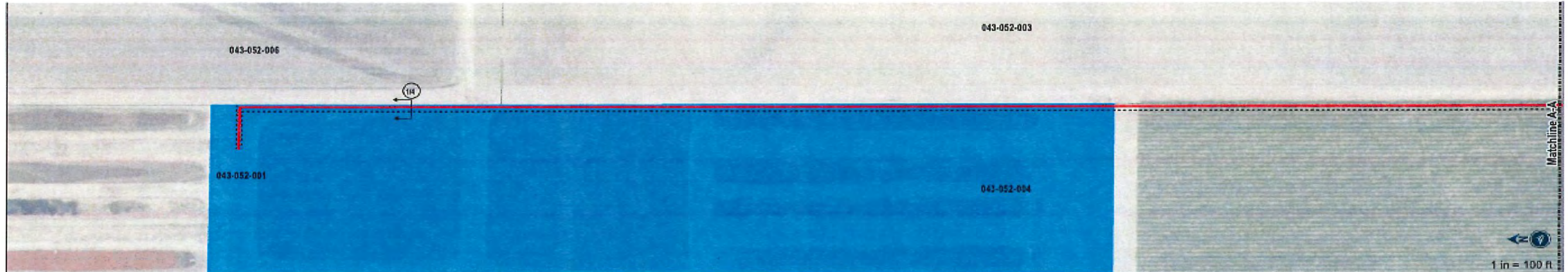

**Legend**

- Parcel
- Name**
- Cal So Partnership - 2017 Grant Easement
- Fuel Cell
- Matchline
- Eriqan Collection Line
- Eriqan 30'
- Eriqan

**Scale Section Callout**

A = DETAIL NUMBER  
B = SHEET NUMBER



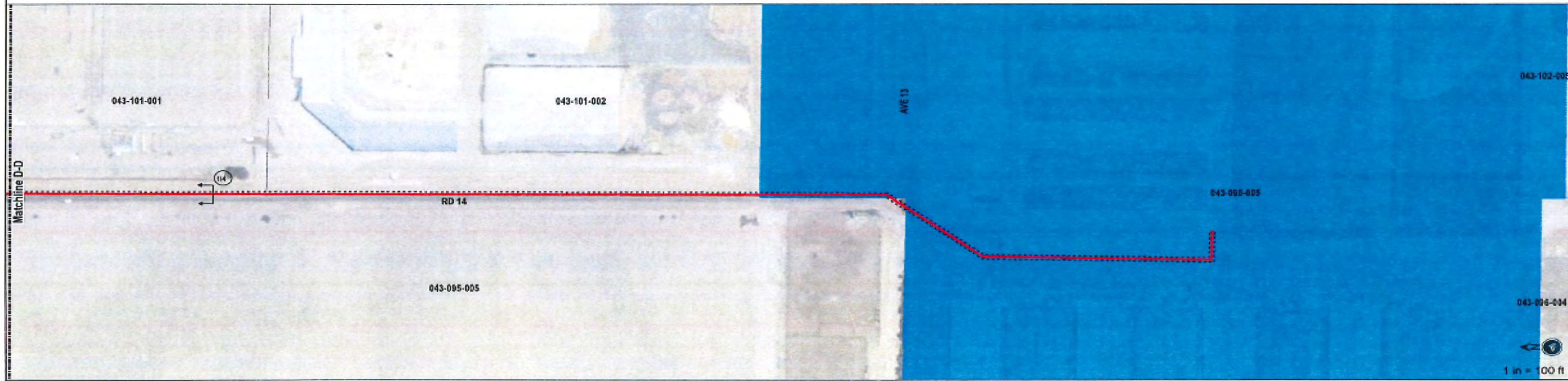
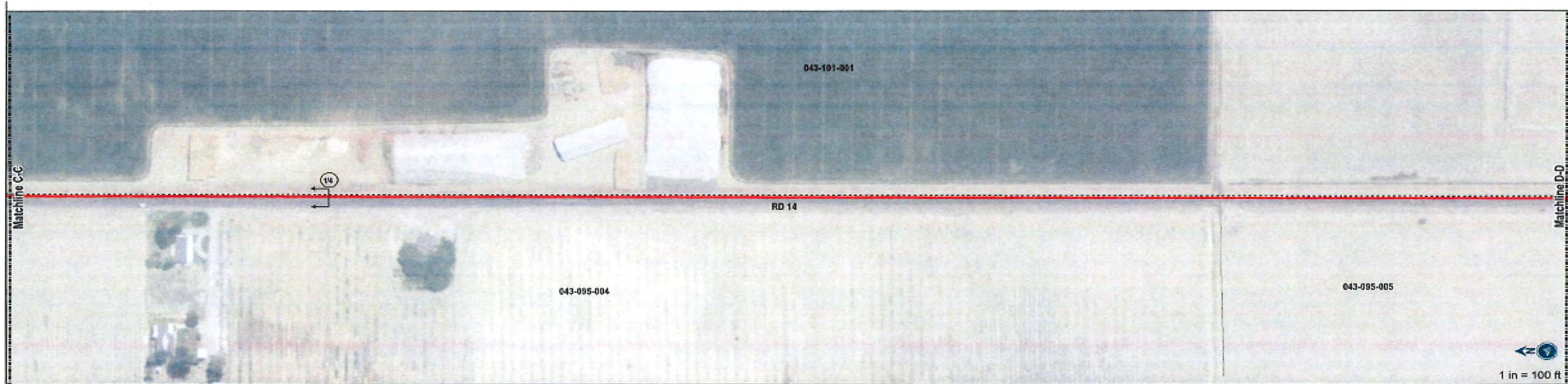

**Legend**

- Parcel
- Name
- Callicia Participant - 2018 Grant Submitted
- Fuel Cell
- Matchline
- Dogma Collection Line
- Estimate 30
- Block

**Cross Section Callout**

A = DETAIL NUMBER  
B = SHEET NUMBER



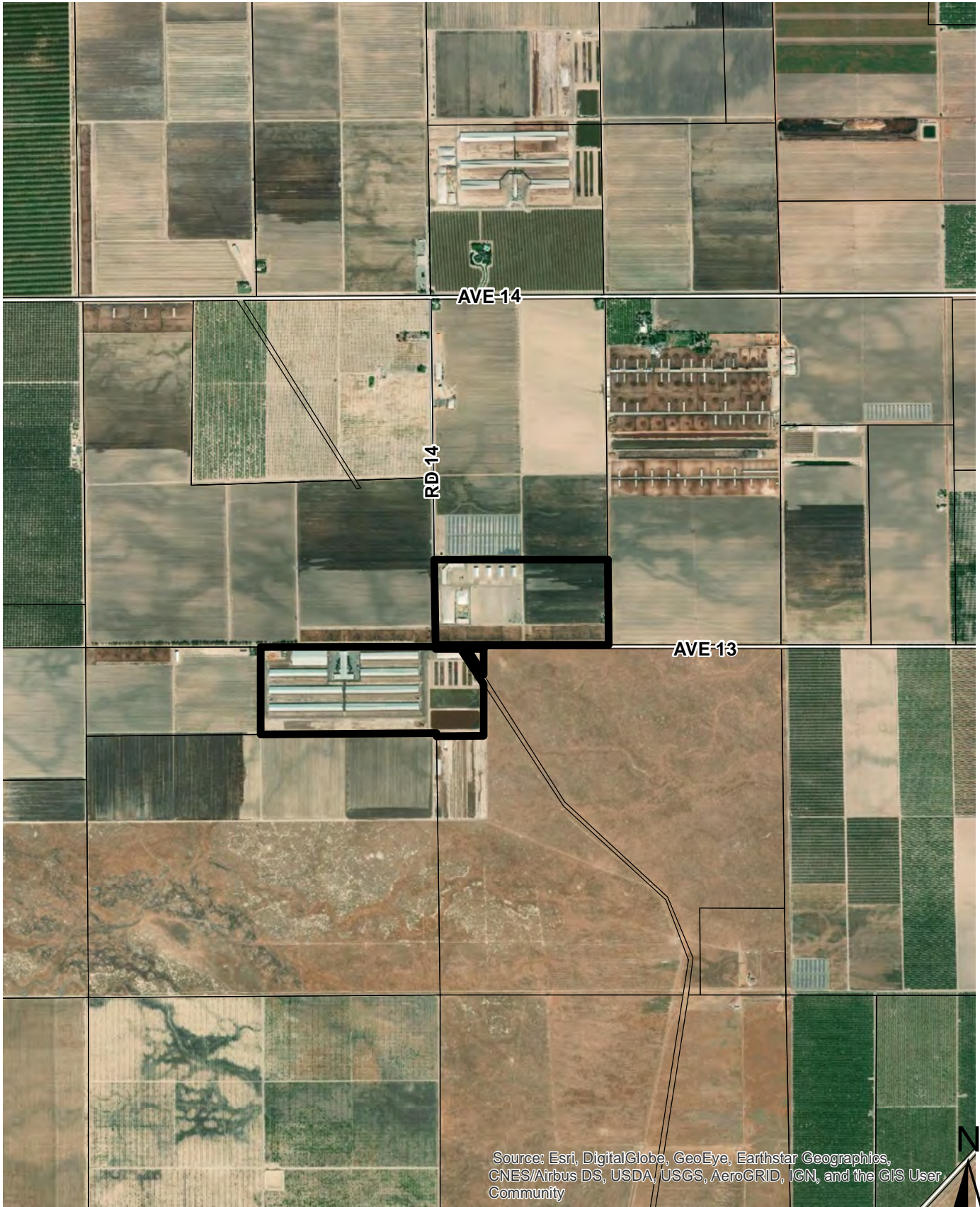

Source: Esri, DigitalGlobe, GeoEye, Earthstar Geographics, CNES/Airbus DS, USDA, USGS, AeroGRID, IGN, and the GIS User Community

**AERIAL MAP**



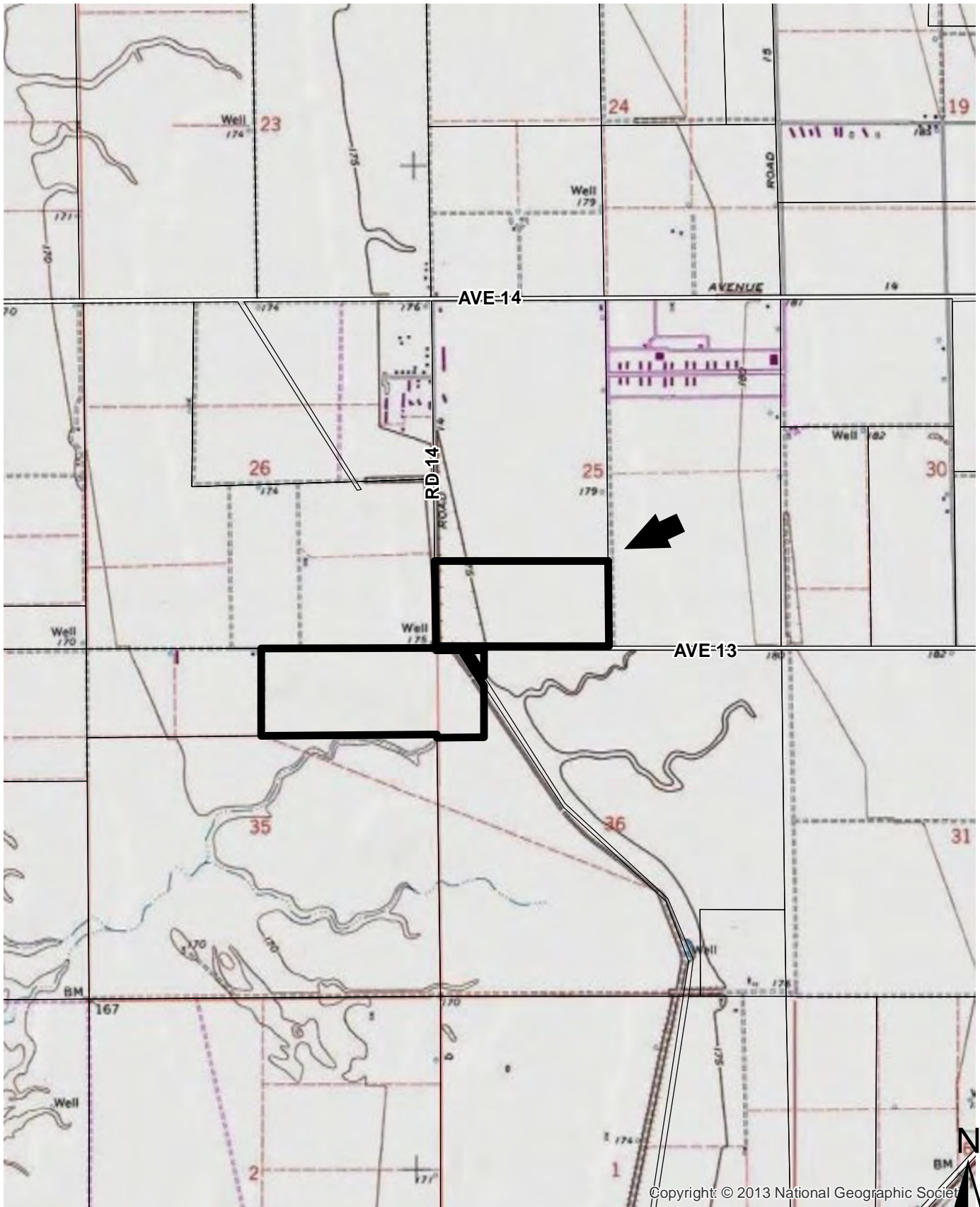

**TOPOGRAPHICAL MAP**



## Community and Economic Development Planning Division

Norman L. Allinder, AICP  
Director

## EXHIBIT G

- 200 W 4<sup>th</sup> Street
- Suite 3100
- Madera, CA 93637
- (559) 675-7821
- FAX (559) 675-6573
- TDD (559) 675-8970
- mc\_planning@madera-county.com

### OPERATIONAL/ENVIRONMENTAL STATEMENT CHECKLIST

It is important that the operational/environmental statement provides for a complete understanding of your project proposal. Please be as detailed as possible.

1. Please provide the following information:

Assessor's Parcel Number: 043-096-005

Applicant's Name: Robert Diepersloot

Address: 14221 Avenue 14, Madera, CA 93637

Phone Number: (559) 664-0940

2. Describe the nature of your proposal/operation.

To amend CUP #2014-014 to allow the construction and operation of an anaerobic digester at South Point Dairy, an existing dairy facility, along with necessary infrastructure for wastewater management. Additionally, it is proposed to construct a low-pressure pipeline to deliver biogas to a proposed Bloom Fuel Cell Energy Server (separate CUP) to be constructed 1.5 mile northwest along Avenue 14.

3. What is the existing use of the property?

Existing dairy facility

4. What products will be produced by the operation? Will they be produced onsite or at some other location? Are these products to be sold onsite?

Biogas from the proposed anaerobic digester will be produced, conditioned to remove H<sub>2</sub>S, and delivered to the Bloom Fuel Cell Energy Server off-site. The current operations also include the production of milk to be hauled off-site.

5. What are the proposed operational time limits?

Months (if seasonal): The digester will operate 365 days per year. However, only one employee will maintain the digester.

Days per week: The digester will operate 365 days per year. However, only one employee will maintain the digester, one day per week, in addition to any equipment utilized by current operations.

Hours (from 8AM to 5PM): Total Hours per day: Up to 8, much less anticipated.

6. How many customers or visitors are expected?

Average number per day: Same as current

Maximum number per day: Same as current

What hours will customers/visitors be there? Same as current

7. How many employees will there be?

Current: Approximately 50

Future: 1 additional

Hours they work: Varies due to operations of the dairy facility, 8 hour shifts.

Do any live onsite? If so, in what capacity (i.e. caretaker)? No

8. What equipment, materials, or supplies will be used and how will they be stored? If appropriate, provide pictures or brochures.

An H2S Scrubber to remove H2S from the biogas, air compressor to compress biogas for low-pressure pipeline delivery, oxygen generator and blower, in addition to any equipment utilized by current operations.

9. Will there be any service and delivery vehicles? Same as current

Number: Same as current

Type: Same as current

Frequency: Same as current

10. Number of parking spaces for employees, customers, and service/delivery vehicles. Type of surfacing on parking area.

Approximately 100 unmarked parking spaces on gravel / DG.

11. How will access be provided to the property/project? (street name)

There are 2 access points from Avenue 13.

12. Estimate the number and type (i.e. cars or trucks) of vehicular trips per day that will be generated by the proposed development.

The proposed development will require one additional trip per week, by standard pickup/service truck.

13. Describe any proposed advertising, including size, appearance, and placement.

None.

14. Will existing buildings be used or will new buildings be constructed? Indicate which building(s) or portion(s) of will be utilized and describe the type of construction materials, height, color, etc. Provide floor plan and elevations, if applicable.

All existing buildings will continue to be utilized as currently operated. The proposed development includes an anaerobic digester and necessary infrastructure for wastewater management, and for biogas conditioning and delivery. All proposed structures are to be built at ground level or below, including some concrete pads for foundation of the proposed equipment.

15. Is there any landscaping or fencing proposed? Describe type and location.

None

16. What are the surrounding land uses to the north, south, east and west property boundaries?

Agricultural farmland

17. Will this operation or equipment used, generate noise above other existing parcels in the area?

No

18. On a daily or annual basis, estimate how much water will be used by the proposed development, and how is water to be supplied to the proposed development (please be specific).

The digester has been designed to intake all wastewater from the facility as currently operated. No additional water use is proposed.



19. On a daily or weekly basis, how much wastewater will be generated by the proposed project and how will it be disposed of?

None in addition to current operations

---

---

20. On a daily or weekly basis, how much solid waste (garbage) will be generated by the proposed project and how will it be disposed of?

None in addition to current operations

---

---

21. Will there be any grading? Tree removal? (please state the purpose, i.e. for building pads, roads, drainage, etc.)

Grading will be needed for the digester, sand lane, and equipment pads. Grading for the sand lane and equipment pads will be minimal.

Grading for the digester will include removal of berms between existing wastewater ponds to construct digester pond according to design.

---

---

22. Are there any archeological or historically significant sites located on this property? If so, describe and show location on site plan.

None known

---

---

23. Locate and show all bodies of water on application plot plan or attached map.

N/A

---

---

24. Show any ravines, gullies, and natural drainage courses on the property on the plot plan.

N/A

---

---

25. Will hazardous materials or waste be produced as part of this project? If so, how will they be shipped or disposed of?

The biogas produced by the digester will be delivered off-site via low pressure biogas pipeline. The biogas is to be conditioned on-site to meet maximum safety standards.

---

---

26. Will your proposal require use of any public services or facilities? (i.e. schools, parks, fire and police protection or special districts?)

No

---

---

27. How do you see this development impacting the surrounding area?

No negative impact anticipated to the surrounding area. The anaerobic digester will reduce the odor of typical dairy operations and provide better air quality by capturing majority of the methane produced by operations, and by processing through the Bloom system, used to generate electricity.

---

---

28. How do you see this development impacting schools, parks, fire and police protection or special districts?

No impacts anticipated.

---

---

29. If your proposal is for commercial or industrial development, please complete the following; Proposed Use(s): Anaerobic digester and equipment for production and conditioning of biogas.

Square feet of building area(s): \_\_\_\_\_

Total number of employees: \_\_\_\_\_

Building Heights: Varies, equipment heights up to 12 feet tall, digester designed for average depth of 25 feet below ground surface.

---

---

**30.** If your proposal is for a land division(s), show any slopes over 10% on the map or on an attached map.

---

---



**Intended Use (describe request clearly):**

To amend CUP #2014-014 to allow the construction and operation of an anaerobic digester at South Point Dairy, an existing dairy facility, along with necessary infrastructure for wastewater management. Additionally, it is proposed to construct a low-pressure pipeline to deliver biogas to a proposed Bloom Fuel Cell Energy Server (separate CUP) to be constructed 1.5 mile northwest along Avenue 14.



Community and Economic Development  
Environmental Health Division

Dexter Marr  
Deputy Director

- 200 W. Fourth St.
- Suite 3100
- Madera, CA 93637
- TEL (559) 661-5191
- FAX (559) 675-6573
- TDD (559) 675-8970

---

MEMORANDUM

TO: Robert Mansfield  
FROM: Dexter Marr, Environmental Health Division  
DATE: May 30, 2019  
RE: South Point Dairy - Conditional Use Permit - Madera (043-101-002-000)

---

Comments

TO: Planning Division  
FROM: Environmental Health Division  
DATE: May 22, 2019  
RE: Conditional Use Permit (CUP) #2019-008, South Point Dairy—Madera, APN: 043096005

---

Environmental Health Division Comments:

The facilities must comply with their Report of Waste Discharge (RWD) requirements under the Regional Water Quality Control Board (RWQCB).

The facility must comply with their San Joaquin Valley Air Pollution Control Board (SJVAPCD) permit.

The facility must comply with Cal Recycle permit requirements for an Anaerobic Digester.

Provide/Update Pest (vector) Management Plan. The Pest (vector) Management Plan must go into detail of how each known vector will be identified, tracked, eliminated or significantly reduced and how this program will be implemented. This Pest Management Plan must be provided for review and approval by this department prior to approving of this CUP to ensure that vector(s) are handled on site to effectively prevent them or at a minimum significantly reduce them from becoming an off-site nuisance.

Provide/Update Odor and Dust Management Plans. The Management Plans must go into detail in describing how odor and dust control will be managed and implemented. The Odor and Dust Management Plans must be provided for review and approval by this department prior to approval of this CUP to ensure that each known dairy nuisance(s) are handled on site to effectively prevent them from moving off-site creating a nuisance.

If your facility handles/store any hazardous materials on-site or generates hazardous waste you may be subject to permitting requirements through our department. As of January 2013 all Certified Unified Program Agency (CUPA) regulated businesses must submit their Hazardous Material Business Plan electronically into the California Environmental Reporting System (CERS) at [www.cers.ca.epa.ca.gov](http://www.cers.ca.epa.ca.gov).

The construction and then ongoing operation must be done in a manner that shall not allow any type of public nuisance(s) to occur including but not limited to the following nuisance(s); Dust, Odor(s), Noise(s), Lighting, Vector(s) or Litter. This must be accomplished under accepted and approved Best Management Practices (BMP) and as required by the County General Plan, County Ordinances and any other related State and/or Federal jurisdiction.

If there are any questions or comments regarding these conditions/requirements or for please, contact this department at (559) 675-7823.

Community and Economic Development  
Fire Prevention Division

Deborah Mahler, Fire Marshal  
Deputy Director

- 200 W. Fourth St.
- Suite 3100
- Madera, CA 93637
- TEL (559) 661-5191
- FAX (559) 675-6573
- TDD (559) 675-8970

---

**MEMORANDUM**

TO: Robert Mansfield  
FROM: Deborah Mahler, Fire Marshal  
DATE: May 30, 2019  
RE: South Point Dairy - Conditional Use Permit - Madera (043-101-002-000)

---

**Conditions**

At the time of application for a Building Permit, a more in-depth plan review of the proposed project's compliance with all current fire and life safety codes will be conducted by the Madera County Fire Marshal. (CFC, Section 105)

June 6, 2019

Robert Mansfield  
County of Madera  
Planning Department  
200 W. 4<sup>th</sup> Street, Suite 3100  
Madera, CA 93637

**Project: Conditional Use Permit #2019-008, South Point Dairy**

**District CEQA Reference No: 20190621**

Dear Mr. Mansfield:

The San Joaquin Valley Unified Air Pollution Control District (District) has reviewed the request for a Conditional Use Permit (CUP) to amend CUP #2014-014 (South Point Dairy) for the project referenced above located at 14495 Road 13 in Madera, CA. The proposed project consists of the construction of an anaerobic digester at an existing dairy facility, along with necessary infrastructure for wastewater management and the addition of a low-pressure pipeline to deliver biogas to a proposed Bloom Fuel Cell Energy Server (Project). The District offers the following comments:

**Emissions Analysis**

- 1) The CEQA referral submitted to the District does not provide sufficient information to allow the District to assess the Project's potential impact on air quality. The District recommends that the County provide a more detailed assessment.
  - a) The District is in receipt of an Authority to Construct application from the applicant for the proposed anaerobic digester. The annual emissions of criteria pollutants from stationary sources for the anaerobic digester are not expected to exceed any of the District thresholds of significance. However, the County's Project Review Request does not provide sufficient information for the pipeline which will connect a planned anaerobic digester cluster to deliver biogas to a proposed Bloom Fuel Cell Energy Server. As such, the District cannot assess the pipeline's potential impact on air quality. The District recommends that the County provide a more detailed assessment for the pipeline project.

**Samir Sheikh**  
Executive Director/Air Pollution Control Officer

---

**Northern Region**  
4800 Enterprise Way  
Modesto, CA 95356-8718  
Tel: (209) 557-6400 FAX: (209) 557-6475

**Central Region (Main Office)**  
1990 E. Gettysburg Avenue  
Fresno, CA 93726-0244  
Tel: (559) 230-6000 FAX: (559) 230-6061

**Southern Region**  
34946 Flyover Court  
Bakersfield, CA 93308-9725  
Tel: 661-392-5500 FAX: 661-392-5585

- 2) The District recommends that the assessment include the following impacts:
- a) **Construction Emissions:** Construction emissions are short-term emissions and should be evaluated separately from operational emissions. For reference, the District's annual criteria thresholds of significance for construction are: 100 tons per year of carbon monoxide (CO), 10 tons per year of oxides of nitrogen (NOx), 10 tons per year of reactive organic gases (ROG), 27 tons per year of oxides of sulfur (SOx), 15 tons per year of particulate matter of 10 microns or less in size (PM10), or 15 tons per year of particulate matter of 2.5 microns or less in size (PM2.5).
    - i) *Recommended Mitigation Measure if needed:* To reduce impacts from construction related exhaust emissions, the District recommends feasible mitigation for the project to utilize off-road construction fleets that can achieve fleet average emissions equal to or cleaner than the Tier III emission standards, as set forth in §2423 of Title 13 of the California Code of Regulations, and Part 89 of Title 40 Code of Federal Regulations. This can be achieved through any combination of uncontrolled engines and engines complying with Tier III and above engine standards.
  - b) **Operational Emissions:** Permitted (stationary sources) and non-permitted (mobile sources) sources should be analyzed separately. For reference, the annual criteria thresholds of significance for operation of permitted and non-permitted sources each are: 100 tons per year of carbon monoxide (CO), 10 tons per year of oxides of nitrogen (NOx), 10 tons per year of reactive organic gases (ROG), 27 tons per year of oxides of sulfur (SOx), 15 tons per year of particulate matter of 10 microns or less in size (PM10), or 15 tons per year of particulate matter of 2.5 microns or less in size (PM2.5).
  - c) **Recommended Model:** Project related criteria pollutant emissions from construction and operation non-permitted (limited to equipment not subject to District permits) should be identified and quantified. Emissions analysis should be performed using CalEEMod (**California Emission Estimator Model**), which uses the most recent approved version of relevant Air Resources Board (ARB) emissions models and emission factors. CalEEMod is available to the public and can be downloaded from the CalEEMod website at: [www.caleemod.com](http://www.caleemod.com).
  - d) **Nuisance Odors:** The Project should be evaluated to determine the likelihood that the Project would result in nuisance odors. Nuisance orders are subjective, thus the District has not established thresholds of significance for nuisance odors. Nuisance odors may be assessed qualitatively taking into consideration of Project design elements and proximity to off-site receptors that potentially would be exposed objectionable odors.
  - e) **Health Risk Screening/Assessment:** A Health Risk Screening/Assessment identifies potential Toxic Air Contaminants (TAC's) impact on surrounding sensitive receptors such as hospitals, daycare centers, schools, work-sites, and residences.



TAC's are air pollutants identified by the Office of Environmental Health Hazard Assessment/California Air Resources Board (OEHHA/CARB) (<https://www.arb.ca.gov/toxics/healthval/healthval.htm>) that pose a present or potential hazard to human health. A common source of TACs can be attributed to diesel exhaust emitted from both mobile and stationary sources. Industry specific TACs generated must also be identified and quantified.

The District recommends the Project be evaluated for potential health impacts to surrounding receptors (on-site and off-site) resulting from operational and multi-year construction TAC emissions.

- i) The District recommends conducting a screening analysis that includes all sources of emissions. A screening analysis is used to identify projects which may have a significant health impact. A prioritization, using CAPCOA's updated methodology, is the recommended screening method. A prioritization score of 10 or greater is considered to be significant and a refined Health Risk Assessment (HRA) should be performed. The prioritization calculator can be found at:  
[http://www.valleyair.org/busind/pto/emission\\_factors/Criteria/Toxics/Utilities/PRIORITIZATION%20RMR%202016.XLS](http://www.valleyair.org/busind/pto/emission_factors/Criteria/Toxics/Utilities/PRIORITIZATION%20RMR%202016.XLS).
- ii) The District recommends a refined HRA for projects that result in a prioritization score of 10 or greater. It is recommended that the Project proponent contact the District to review the proposed modeling protocol. The Project would be considered to have a significant health risk if the HRA demonstrates that the project related health impacts would exceed the District's significance threshold of 20 in a million for carcinogenic risk and 1.0 for the Acute and Chronic Hazard Indices.

Please provide the following information electronically to the District for review:

- HRA AERMOD model files
- HARP2 files
- Summary of emissions source locations, emissions rates, and emission factor calculations and methodology.

More information on toxic emission factors, prioritizations and HRAs can be obtained by:

- E-Mailing inquiries to: [hramodeler@valleyair.org](mailto:hramodeler@valleyair.org); or
- The District can be contacted at (559) 230-6000 for assistance; or
- Visiting the District's website (Modeling Guidance) at [http://www.valleyair.org/busind/pto/Tox\\_Resources/AirQualityMonitoring.htm](http://www.valleyair.org/busind/pto/Tox_Resources/AirQualityMonitoring.htm)

- f) **Ambient Air Quality Analysis:** An ambient air quality analysis (AAQA) uses air dispersion modeling to determine if emissions increases from a project will cause or

contribute to a violation of the ambient air quality standards. The District recommends that an AAQA be performed for the Project if emissions exceed 100 pounds per day of any pollutant.

If an AAQA is performed, the analysis should include emissions from both Project specific permitted and non-permitted equipment and activities. The District recommends consultation with District staff to determine the appropriate model and input data to use in the analysis. Specific information for assessing significance, including screening tools and modeling guidance is available online at the District's website [www.valleyair.org/ceqa](http://www.valleyair.org/ceqa).

### **District Rules and Regulations**

- 3) The proposed Project may be subject to the following District rules: Regulation VIII (Fugitive PM10 Prohibitions), Rule 4102 (Nuisance), Rule 4601 (Architectural Coatings), and Rule 4641 (Cutback, Slow Cure, and Emulsified Asphalt, Paving and Maintenance Operations). In the event an existing building will be renovated, partially demolished or removed, the Project may be subject to District Rule 4002 (National Emission Standards for Hazardous Air Pollutants). The following rules are specific to confined animal operations:
- Rule 4102 (Nuisance) – This rule applies to any source operation that emits or may emit air contaminants or other materials. In the event that the Project or construction of the Project creates a public nuisance, it could be in violation and be subject to District enforcement action.
  - Rule 4550 (Conservation Management Practices) – The purpose of this rule is to limit fugitive dust emissions from agricultural operation sites. These sites include areas of crop production, animal feeding operations and unpaved roads/equipment areas. The District's CMP handbook can be found online at the District's website at: [http://www.valleyair.org/farmpermits/updates/cmp\\_handbook.pdf](http://www.valleyair.org/farmpermits/updates/cmp_handbook.pdf).
  - Rule 4570 (Confined Animal Facilities) – District Rule 4570 was adopted by the District's Governing Board on June 15, 2006. Dairies with greater than or equal to 500 milk cows are subject to the requirements of District Rule 4570. Therefore, a Rule 4570 application shall also be submitted to the District.

The above list of rules is neither exhaustive nor exclusive. To identify other District rules or regulations that apply to this Project or to obtain information about District permit requirements, the applicant is encouraged to contact the District's Small Business Assistance Office at (559) 230-5888. Current District rules can be found online at: [www.valleyair.org/rules/1ruleslist.htm](http://www.valleyair.org/rules/1ruleslist.htm).

District staff is available to meet with you and/or the applicant to discuss the regulatory requirements that are associated with this Project. If you have any questions or require

further information, please call Michael Corder at (559) 230- 5818 and provide the reference number at the top of the letter.

Sincerely,

Arnaud Marjollet  
Director of Permit Services



Brian Clements  
Program Manager

AM: mc

**Robert Mansfield**

---

**From:** Tammali, Balraj@Waterboards <Balraj.Tammali@Waterboards.ca.gov>  
**Sent:** Friday, June 7, 2019 10:59 AM  
**To:** Robert Mansfield  
**Subject:** FW: Comments on Conditional Use Permits #2019-007,008, & 009

**From:** Tammali, Balraj@Waterboards  
**Sent:** Friday, June 07, 2019 10:56 AM  
**To:** robert-mansfield@madera-county.com  
**Cc:** Essary, Dale@Waterboards <dale.essary@waterboards.ca.gov>; Patteson, Doug@Waterboards <doug.patteson@waterboards.ca.gov>  
**Subject:** Comments on Conditional Use Permits #2019-007,008, & 009

Robert,

We have no comment on Conditional Use Permit Application Nos. 2019-007,008, and 009 for Capstone Dairy, South Point Dairy and the associated Hub at the central location of both the Dairies in Madera County.

Best regards,

**Balraj Tammali, P.E., M.S.**  
Water Resource Control Engineer  
Central Valley Regional Water Quality Control Board  
1685 E Street  
Fresno, CA 93706  
559-445-5156



# TABLE MOUNTAIN RANCHERIA

---

## TRIBAL GOVERNMENT OFFICE

CERTIFIED 7522 8602

June 20, 2019

Leanne Walker-Grant  
Tribal Chairperson

Beverly J. Hunter  
Tribal Vice-Chairperson

Craig Martinez  
Tribal Secretary/Treasurer

Matthew W. Jones  
Tribal Council Member

Richard L. Jones  
Tribal Council Member

Robert Mansfield  
Madera County, Planning Department  
200 West 4<sup>th</sup> Street  
Madera, Ca. 93637

RE: Conditional Use Permit, Madera 043-101-002-000

Dear: Robert Mansfield

Table Mountain Rancheria is responding to your letter dated, May 13, 2019, regarding, Conditional Use Permit, Madera 043-101-002-000. Thank you for notifying Table Mountain Rancheria of the potential development and request for consultation. The Rancheria is very interested in this project as it lies within our cultural area of interest.

If you have already conducted a record search, please provide Table Mountain Rancheria with copies of any cultural resource report you may have.

At this time, please contact our office at (559) 325-0351 or [rpennell@tmr.org](mailto:rpennell@tmr.org) to coordinate a discussion and meeting date regarding your project.

Sincerely,

A handwritten signature in blue ink, appearing to read "Robert Pennell", is written over a light blue horizontal line.

Robert Pennell  
Tribal Cultural Resources Director

23736  
Sky Harbour Road  
Post Office  
Box 410  
Friant  
California  
93626  
(559) 822-2587  
Fax  
(559) 822-2693

**County of Madera**  
**California Environmental Quality Act (CEQA)**  
**Initial Study**

- 1. Project title:** CUP #2019-008 – South Point Dairy
- 2. Lead agency name and address:** County of Madera  
Community and Economic Development Department  
200 West 4<sup>th</sup> Street, Suite 3100  
Madera, California 93637
- 3. Contact person and phone number:** Robert Mansfield, AICP, Senior Planner  
559-675-7821  
Robert.mansfield@maderacounty.com
- 4. Project Location & APN:** The subject property is located on the north side of Avenue 13, approximately 1.47 miles west of its intersection with Road 16 (14495 Avenue 13) Madera.  
  
043-101-002, 043-096-005
- 5. Project sponsor's name and address:** South Point Dairy  
14495 Avenue 13  
Madera, CA 93637
- 6. General Plan Designation:** AE (Agricultural Exclusive) Designation
- 7. Zoning:** ARE-40 (Agricultural, Rural, Exclusive – 40 Acre) District
- 8. Description of project:**

This is a request to amend CUP #2014-014 to allow the construction and operation of an anaerobic digester at South Point Dairy, an existing dairy facility, along with necessary infrastructure for wastewater management. Additionally, it is proposed to construct a low-pressure pipeline to deliver biogas to a proposed Bloom Fuel Cell Energy Server (separate CUP) to be constructed 1.5 miles northwest along Avenue 14. The pipeline will be constructed underground with a minimum 36" (thirty-six inches) of cover (or deeper at crossings as needed).

An anaerobic digester refers to an airtight vessel where "anaerobic" bacteria (i.e. those that thrive in the absence of oxygen) are used to digest (e.g. decompose or breakdown) an organic, carbon based, solid waste slurry, such as cow manure or food wastes, into smaller molecular weight compounds with lower residual odor. The anaerobic bacteria generate both methane ( $CH_4$ , also called nature gas) and carbon dioxide ( $CO_2$ ) gases in near equal volume as they digest the waste material. In modern anaerobic digesters, this biogas is captured and is used for energy recovery, typically in an internal combustion engine coupled to an electric generator. During the subsequent combustion, the methane is converted to carbon dioxide, releasing energy to drive the engine or provide heat for other uses.

Existing Conditions:

The existing parcels, and land surrounding the parcels, generally consist of agricultural and open space, with urban uses concentrated mostly around the cities of Madera and Chowchilla. The area is relatively flat and has alluvial groundwater basins and generally provide a steady supply of water.

The area where the dairy's located includes a large portion of western Madera County. The climate of this region is characterized by hot, dry summers and cool, wet winters. Urban areas are centered within the cities of Madera and Chowchilla, while the remaining portions of the area are characterized as agricultural lands. The San Joaquin River delineates the area boundary to the south and west, while the northern boundary is established by the Chowchilla River. The Fresno River and Chowchilla Canal are other major water bodies in the area.

**9. Surrounding Land Uses and Setting:**

Agricultural

**10. Other Public Agencies Whose Approval is Required:**

None

**11. Have California Native American tribes traditionally and culturally affiliated with the project area requested consultation pursuant to Public Resources Code Section 21080.3.1? If so, is there a plan for consultation that includes, for example, the determination of significance of impacts to tribal cultural resources, procedures regarding confidentiality, etc.?**

Under AB 52, Tribal Governments that have requested to be notified of any ministerial projects being processed have been notified pursuant to those requirements. (See Section XVIII for additional discussion.)

**ENVIRONMENTAL FACTORS POTENTIALLY AFFECTED**

The environmental factors checked below would be potentially affected by this project, involving at least one impact that is a "Potentially Significant Impact" as indicated by the checklist on the following pages.

- |  |  |   |
|--|--|---|
| <input type="checkbox"/> Aesthetics                | <input type="checkbox"/> Agricultural/Forestry Resources | <input type="checkbox"/> Air Quality                        |
| <input type="checkbox"/> Biological Resources      | <input type="checkbox"/> Cultural Resources              | <input type="checkbox"/> Energy                             |
| <input type="checkbox"/> Geology/Soils             | <input type="checkbox"/> Greenhouse Gas Emissions        | <input type="checkbox"/> Hazards & Hazardous Materials      |
| <input type="checkbox"/> Hydrology/Water Quality   | <input type="checkbox"/> Land Use/Planning               | <input type="checkbox"/> Mineral Resources                  |
| <input type="checkbox"/> Noise                     | <input type="checkbox"/> Population/Housing              | <input type="checkbox"/> Public Services                    |
| <input type="checkbox"/> Recreation                | <input type="checkbox"/> Transportation                  | <input type="checkbox"/> Tribal Cultural Resources          |
| <input type="checkbox"/> Utilities/Service Systems | <input type="checkbox"/> Wildfire                        | <input type="checkbox"/> Mandatory Findings of Significance |

<b>DETERMINATION</b> (to be completed by Lead Agency)	
On the basis of this initial evaluation:	
<input type="checkbox"/>	I find that the proposed project COULD NOT have a significant effect on the environment, and a NEGATIVE DECLARATION will be prepared.
<input checked="" type="checkbox"/>	I find that although the proposed project could have a significant effect on the environment, there will not be a significant effect in this case because revisions in the project have been made or agreed to by the project proponent. A MITIGATED NEGATIVE DECLARATION will be prepared.
<input type="checkbox"/>	I find that the proposed project MAY have a significant effect on the environment, and an ENVIRONMENTAL IMPACT REPORT is required.
<input type="checkbox"/>	I find that the proposed project MAY have a "potentially significant impact" or "potentially significant unless mitigated" impact on the environment, but at least one effect 1) has been adequately analyzed in an earlier document pursuant to applicable legal standards, and 2) has been addressed by mitigation measures based on the earlier analysis as described on attached sheets. An ENVIRONMENTAL IMPACT REPORT is required, but it must analyze only the effects that remain to be addressed.
<input type="checkbox"/>	I find that although the proposed project could have a significant effect on the environment, because all potentially significant effects (a) have been analyzed adequately in an earlier EIR or NEGATIVE DECLARATION pursuant to applicable standards, and (b) have been avoided or mitigated pursuant to that earlier EIR or NEGATIVE DECLARATION, including revisions or mitigation measures that are imposed upon the proposed project, nothing further is required.

Signed:  Date: June 20, 2019



	Potentially Significant Impact	Less Than Significant With Mitigation Incorporation	Less Than Significant Impact	No Impact
--	--------------------------------	---	------------------------------	-----------

**I. AESTHETICS**

Except as provided in Public Resources Code Section 21099, would the project:

- |   |                          |                          |                                     |                                     |
|---|--------------------------|--------------------------|-------------------------------------|-------------------------------------|
| a) Have a substantial adverse effect on a scenic vista?   | <input type="checkbox"/> | <input type="checkbox"/> | <input type="checkbox"/>            | <input checked="" type="checkbox"/> |
| b) Substantially damage scenic resources, including, but not limited to, trees, rock outcroppings, and historic buildings within a state scenic highway?  | <input type="checkbox"/> | <input type="checkbox"/> | <input type="checkbox"/>            | <input checked="" type="checkbox"/> |
| c) In non-urbanized areas, substantially degrade the existing visual character or quality of public views of the site and its surroundings? (Public views are those that are experienced from publicly accessible vantage point). If the project is in an urbanized area, would the project conflict with applicable zoning and other regulations governing scenic quality? | <input type="checkbox"/> | <input type="checkbox"/> | <input type="checkbox"/>            | <input checked="" type="checkbox"/> |
| d) Create a new source of substantial light or glare which would adversely affect day or nighttime views in the area?   | <input type="checkbox"/> | <input type="checkbox"/> | <input checked="" type="checkbox"/> | <input type="checkbox"/>            |

**Responses:**

Regional views in the western portion of Madera County are characterized by the broad plains of the Central Valley and Sierra Foothills. Lower-elevation views in the region are generally rural in nature with concentrated pockets of small communities. Higher-elevation views in the region include the edge of the Coast Mountain range to the west, Sierra Nevada range to the east, and the Tehachapi Mountains to the south. The primary scenic resources in the County include the ridgelines and steep slopes of the prominent major relief features, such as the mountain ranges listed above, as well as undeveloped rural areas that have retained their nature and scenic integrity.

Land uses common in the area include orchards, vineyards, vacant/fallow grazing land, scattered rural residential areas, existing dairy and agricultural structures/facilities, roadways and the natural riparian habitat of the San Joaquin River and other local waterways.

Dairy digesters typically are constructed at ground level, with pits typical of dairy waste water management practices. All proposed structures related to the project are to be built at ground level or below, including some concrete pads for foundation of the proposed equipment.

**(a - c) No Impact.** There are no scenic vistas by the true definition (a scene, view, or panorama of a particular area) in the vicinity of the project site.

The closest areas that are being considered as scenic highways by the California Department of Transportation (CALTRANS) are Highways 41 and 49 north of Oakhurst.

The dairy is located in the western portion of the County, where the terrain is generally flat and without distinguishing topographic features. The area is characterized by a variety of existing open space and agricultural land uses including other dairies and agricultural operations with similar structures and facilities.

A typical dairy facility would include project structures and buildings on site. Views experienced by motorists on nearby roads would be of the dairy structures, the main dairy barn, and shaded corrals in front of the property. The other structures toward the back of the typical dairy facility, such as the sides of the ponds and commodity barn, would not be typically be readily visible to passing motorists. There are also the occasional single family residence.

This is an existing dairy facility, and is only adding an anaerobic digester to capture methane production from decomposing manure, therefore no aesthetics will be impacted. With conditions of approval and mitigations, this impact will remain as less than significant.

**(d) Less Than Significant Impact.** A nighttime sky in which stars are readily visible is often considered a valuable scenic/visual resource. In urban areas, views of the nighttime sky are being diminished by "light pollution." Light pollution, as defined by the International dark-Sky Association, is any adverse effect of artificial light, including sky glow, glare, light trespass, light clutter, decreased visibility at night, and energy waste. Two elements of light pollution may affect city residents: sky glow and light trespass. Sky glow is a result of light fixtures that emit a portion of their light directly upward into the sky where light scatters, creating an orange-yellow glow above a city or town. This light can interfere with views of the nighttime sky and can diminish the number of stars that are visible. Light trespass occurs when poorly shielded or poorly aimed fixtures cast light into unwanted areas, such as neighboring property and homes.

Light pollution is a problem most typically associated with urban areas. Lighting is necessary for nighttime viewing and for security purposes. However, excessive lighting or inappropriately designed lighting fixtures can disturb nearby sensitive land uses through indirect illumination. Land uses which are considered "sensitive" to this unwanted light include residences, hospitals, and care homes.

Daytime sources of glare include reflections off of light-colored surfaces, windows, and metal details on cars traveling on nearby roadways. The amount of glare depends on the intensity and direction of sunlight, which is more acute at sunrise and sunset because the angle of the sun is lower during these times.

Minimal lighting may occur as a result of this project.

Potentially Significant Impact	Less Than Significant With Mitigation Incorporation	Less Than Significant Impact	No Impact
--------------------------------------	--	------------------------------------	--------------

**II. AGRICULTURAL AND FORESTRY RESOURCES**

In determining whether agricultural impacts to agricultural resources are significant environmental effects, lead agencies may refer to the California Agricultural Land Evaluation and Site Assessment Model (1997) prepared by the California Dept. of Conservation as an optional model to use in assessing impacts on agriculture and farmland. In determining whether impacts to forest resources, including timberland, are significant environmental effects, lead agencies may refer to information compiled by the California Department of Forestry and Fire Protection regarding the state's inventory of forest land, including the Forest and Range Assessment Project and the Forest Legacy Assessment Project; and forest carbon measurement methodology provided in Forest Protocols adopted by the California Air Resources Board.

Would the project:

- |  |                          |                          |                          |                                     |
|--|--------------------------|--------------------------|--------------------------|-------------------------------------|
| a) Convert Prime Farmland, Unique Farmland, or Farmland of Statewide Importance (Farmland), as shown on the maps prepared pursuant to the Farmland Mapping and Monitoring Program of the California Resources Agency, to non-agricultural use?   | <input type="checkbox"/> | <input type="checkbox"/> | <input type="checkbox"/> | <input checked="" type="checkbox"/> |
| b) Conflict with existing zoning for agricultural use, or a Williamson Act contract?   | <input type="checkbox"/> | <input type="checkbox"/> | <input type="checkbox"/> | <input checked="" type="checkbox"/> |
| c) Conflict with existing zoning for, or cause rezoning of, forest land (as defined in Public Resources Code section 12220(g)), timberland (as defined by Public Resources Code section 4526), or timberland zoned Timberland Production (as defined by Government Code section 51104(g))? | <input type="checkbox"/> | <input type="checkbox"/> | <input type="checkbox"/> | <input checked="" type="checkbox"/> |
| d) Result in the loss of forest land or conversion of forest land to non-forest use?   | <input type="checkbox"/> | <input type="checkbox"/> | <input type="checkbox"/> | <input checked="" type="checkbox"/> |
| e) Involve other changes in the existing environment which, due to their location or nature, could result in conversion of Farmland, to non-agricultural use or conversion of forest land to non-forest use?   | <input type="checkbox"/> | <input type="checkbox"/> | <input type="checkbox"/> | <input checked="" type="checkbox"/> |

**Responses:**

Land uses common in the area include orchards, vineyards, vacant/fallow grazing land, scattered rural residential areas, existing dairy and agricultural structures/facilities, roadways and the natural riparian habitat of the San Joaquin River and other local waterways.

**(a - e) No Impact.** The project parcels and their surroundings are not zoned for timberland uses, so there will be no impacts. Under the Farmland Mapping and Monitoring Program of the California Resources Agency, the parcel is designated as Confined Animal Agriculture (CL). Confined animal agriculture includes dairies.

The proposed project would not result in the conversion of farmland, or in this case Confined Animal Agriculture, to non-agriculture use. Construction and operation of dairies, and incidental facilities identical to this one, is permitted under the County's Zoning Ordinance.

The parcel is under a Williamson Act Contract. Due to the fact that this is a functioning dairy, and dairy digesters are typically considered a use typical of dairies, there is no impact to the Williamson Act.

### **General Information**

The California Land Conservation Act of 1965 -- commonly referred to as the Williamson Act -- enables local governments to enter into contracts with private landowners for the purpose of restricting specific parcels of land to agricultural or related open space use. In return, landowners receive property tax assessments which are much lower than normal because they are based upon farming and open space uses as opposed to full market value.

The Department of Conservation oversees the Farmland Mapping and Monitoring Program. The Farmland Mapping and Monitoring Program (FMMP) produces maps and statistical data used for analyzing impacts on California's agricultural resources. Agricultural land is rated according to soil quality and irrigation status; the best quality land is called Prime Farmland. The maps are updated every two years with the use of a computer mapping system, aerial imagery, public review, and field reconnaissance. The program's definition of land is below:

**PRIME FARMLAND (P):** Farmland with the best combination of physical and chemical features able to sustain long term agricultural production. This land has the soil quality, growing season, and moisture supply needed to produce sustained high yields. Land must have been used for irrigated agricultural production at some time during the four years prior to the mapping date.

**FARMLAND OF STATEWIDE IMPORTANCE (S):** Farmland similar to Prime Farmland but with minor shortcomings, such as greater slopes or less ability to store soil moisture. Land must have been used for irrigated agricultural production at some time during the four years prior to the mapping date.

**UNIQUE FARMLAND (U):** Farmland of lesser quality soils used for the production of the state's leading agricultural crops. This land is usually irrigated, but may include no irrigated orchards or vineyards as found in some climatic zones in California. Land must have been cropped at some time during the four years prior to the mapping date.

**FARMLAND OF LOCAL IMPORTANCE (L):** Land of importance to the local agricultural economy as determined by each county's board of supervisors and a local advisory committee.

GRAZING LAND (G): Land on which the existing vegetation is suited to the grazing of livestock. This category was developed in cooperation with the California Cattlemen's Association, University of California Cooperative Extension, and other groups interested in the extent of grazing activities. The minimum mapping unit for Grazing Land is 40 acres.

URBAN AND BUILT-UP LAND (D): Land occupied by structures with a building density of at least 1 unit to 1.5 acres, or approximately 6 structures to a 10-acre parcel. This land is used for residential, industrial, commercial, institutional, public administrative purposes, railroad and other transportation yards, cemeteries, airports, golf courses, sanitary landfills, sewage treatment, water control structures, and other developed purposes.

OTHER LAND (X): Land not included in any other mapping category. Common examples include low density rural developments; brush, timber, wetland, and riparian areas not suitable for livestock grazing; confined livestock, poultry or aquaculture facilities; strip mines, borrow pits; and water bodies smaller than 40 acres. Vacant and nonagricultural land surrounded on all sides by urban development and greater than 40 acres is mapped as Other Land.

---

	Potentially Significant Impact	Less Than Significant With Mitigation Incorporation	Less Than Significant Impact	No Impact
--	--------------------------------------	---	------------------------------------	--------------

**III. AIR QUALITY**

Where available, the significance criteria established by the applicable air quality management district or air pollution control district may be relied upon to make the following determinations. Would the project:

- |   |                          |                          |                                     |                                     |
|---|--------------------------|--------------------------|-------------------------------------|-------------------------------------|
| a) Conflict with, or obstruct implementation of, the applicable air quality plan?   | <input type="checkbox"/> | <input type="checkbox"/> | <input checked="" type="checkbox"/> | <input type="checkbox"/>            |
| b) Result in a cumulatively considerable net increase of any criteria pollutant for which the project region is non-attainment under an applicable federal or state ambient air quality standard? | <input type="checkbox"/> | <input type="checkbox"/> | <input type="checkbox"/>            | <input checked="" type="checkbox"/> |
| c) Expose sensitive receptors to substantial pollutant concentrations?  | <input type="checkbox"/> | <input type="checkbox"/> | <input checked="" type="checkbox"/> | <input type="checkbox"/>            |
| d) Result in other emissions (such as those leading to odors) adversely affecting a substantial number of people?   | <input type="checkbox"/> | <input type="checkbox"/> | <input checked="" type="checkbox"/> | <input type="checkbox"/>            |

**Responses:**

The primary factors that determine air quality are the locations of air pollutant sources and the amounts of pollutants emitted. Meteorological and topographical conditions, however, also are important. Factors such as wind speed and direction, and air temperature gradients interact with physical landscape features to determine the movement and dispersal of criteria air pollutants.

The area where the majority of dairies within Madera County lies within the San Joaquin Valley Air Basin (SJVAB), basically a flat area bordered on the east by the Sierra Nevada Mountains; on the west by the Coast Ranges; and to the south by the Tehachapi Mountains. Airflow in the SJVAB is primarily influenced by marine air that enters through the Carquinez Straits where the San Joaquin-Sacramento Delta empties into the San Francisco Bay. The region's topographic features restrict air movement through and out of the basin. As a result, the SJVAB is highly susceptible to pollutant accumulation over time. Frequent transport of pollutants into the SJVAB from upwind sources also contributes to poor air quality.

Wind speed and direction play an important role in dispersion and transport of air pollutants. During summer periods, winds usually originate from the north end of the San Joaquin Valley and flows in a south-southeasterly direction through the valley, through the Tehachapi pass and into the neighboring Southeast Desert Air Basin. During winter months, winds occasionally originate from the south end of the valley and flow in a north-northwesterly direction. Also, during winter months, the valley experiences light, variable winds, less than 10 miles per hour (mph). Low wind speeds, combined with low inversion layers in the winter, create a climate conducive to high concentrations of certain air pollutants.

The SJVAB has an inland Mediterranean climate that is characterized by warm, dry summers and cooler winters. Summer high temperatures often exceed 100 degrees Fahrenheit, averaging from the low 90s in the northern part of the valley to the high 90s in the south. The daily summer temperature variation can be as high as 30 degrees Fahrenheit. Winters are for the most part mild and humid. Average high temperatures during the winter are in the 50s, while the average daily low temperature is in the 40s.

The vertical dispersion of air pollutants in the valley is limited by the presence of persistent temperature inversions. Air temperatures usually decrease with an increase in altitude. A reversal of this atmospheric state, where the air temperature increases with height, is termed an inversion. Air above and below an inversion does not mix because differences in air density restrict air pollutant dispersal.

Dairy manure digester and co-digester products can generate usable methane, a renewable energy resource, and also reduce greenhouse gas emissions. The Central Valley is home to approximately 1,400 dairies with about 1.6 million cows. Dairy digesters will directly advance California's major environmental goals of reducing GHG emissions and generating biogas to meet the State's Renewable Portfolio Standard goals.

Gases that trap heat in the atmosphere are called greenhouse gases. Carbon dioxide and methane are greenhouse gases that would result from dairies. Carbon dioxide is the first-most significant greenhouse gas that contributes to the concept of global warming, followed by methane. Carbon dioxide is generated by all material combustion and would be associated with dairies through the operation of trucks, mobile equipment and automobiles. Methane is emitted into the environment from various sources, including ruminant livestock and manure decomposition. Methane generation from ruminant animals is influenced by feed quality, essential nutrients in the feed, feeding level and schedule, and animal health. Although not a criteria pollutant, ammonia is a Toxic Air Contaminant (TAC) and is considered a precursor to  $PM_{2.5}$ . Ammonia is generated during anaerobic decomposition of manure and is therefore of interest in evaluating the air quality impacts related to dairies.

Gases from the decomposition of manure is not commonly thought of as a hazardous waste or material in the traditional definitions. However, they do have the potential of causing serious health issues in large enough quantities and in enclosed facilities. Fatal or serious inhalation hazards of gases including hydrogen sulfide ( $H_2S$ ), carbon dioxide ( $CO_2$ ), methane ( $CH_4$ ), and ammonia ( $NH_3$ ) may exist where manure gases are generated through the handling of liquid or semi-solid manure through activities such as pumping, mixing, agitating, spreading, or cleaning-out. Oxygen deficiencies are an additional related concern.

Hydrogen sulfide ( $H_2S$ ) will be conditioned out of the biogas before being sent to the Bloom Fuel Energy segment of the project. The biogas is transported via underground low-pressure pipeline.

**(a, c - d) Less Than Significant Impact.** The anaerobic digester will capture methane from decomposing manure sourced from the dairy facility and then converted to electricity which will be sold to an off-site electrical provider. Anaerobic digestion is a process by which microorganisms break down biodegradable material in the absence of oxygen. The process produces a biogas consisting of methane, carbon dioxide and traces of other gases. The process is widely used as a source of renewable energy. The biogas generated from the site will eventually be turned in to electricity which will then be sold to the power grid.

Biogas typically refers to a gas produced by the biological breakdown of organic matter in the absence of oxygen. Organic waste such as dead plant and animal material, animal feces, and kitchen waste can be converted to a gaseous fuel called biogas. It comprises primarily methane and carbon dioxide and may have small amounts of hydrogen sulfide and moisture. The process is a three step procedure. First is the decomposition of plant or animal matter, this step breaks down the organic material to usable sized molecules such as sugar. The second step is the conversion of decomposed matter to organic acids. Lastly, those acids are converted to methane gas.

A part of the project consists of going through a conditioning process that will remove  $H_2S$  (hydrogen sulfide – the “rotten egg” odor). Hydrogen sulfide is often produced by microbial breakdown in the absence of oxygen gas. This process is commonly known as anaerobic digestion. Once the  $H_2S$  has been removed, the remaining biogas will be transported to the Bloom Fuel Cell Energy Server.

There will be construction activity during the period the digester is installed on site. There may be some impacts as a result of the construction but is expected to be minimal and only for the duration of the construction.

Sensitive receptors are facilities that “house or attract children, the elderly, people with illnesses, or others who are especially sensitive to the effects of air pollution. Hospitals, schools, convalescent facilities and residential areas are examples of sensitive receptors.” (GAMAQI, 2002). The area is not densely populated, but there are residences in close proximity.

With mitigations and conditions of approval, this impact will remain less than significant.

**(b) No Impact.** No impacts have been identified as a result of this project. While there is a tendency for dairies to fluctuate in the number of head on the facility site, there is no substantial increase projected as a result of this project, therefore no increase in criteria pollutants. No additional vehicular trips are anticipated once in operation.

There may be some construction related emissions for purposes of the digester on-site as well as the related pipeline, but these are anticipated to be minimal in the long term and temporary for the duration of construction.



As designed, the San Joaquin Valley Air Pollution Control District has indicated that the annual emissions from the stationary source (digester) is not expected to exceed any of the District thresholds of significance.

**IV. BIOLOGICAL RESOURCES**

Would the project:

	Potentially Significant Impact	Less Than Significant With Mitigation Incorporation	Less Than Significant Impact	No Impact
a) Have a substantial adverse effect, either directly or through habitat modifications, on any species identified as a candidate, sensitive, or special status species in local or regional plans, policies or regulations, or by the California Department of Fish and Game or U.S. Fish and Wildlife Service?	<input type="checkbox"/>	<input type="checkbox"/>	<input type="checkbox"/>	<input checked="" type="checkbox"/>
b) Have a substantial adverse effect on any riparian habitat or other sensitive natural community identified in local or regional plans, policies, regulations, or by the California Department of Fish and Game or U.S. Fish and Wildlife Service?	<input type="checkbox"/>	<input type="checkbox"/>	<input type="checkbox"/>	<input checked="" type="checkbox"/>
c) Have a substantial adverse effect on state or federally protected wetlands (including, but not limited to, marsh, vernal pool, coastal, etc.) through direct removal, filling, hydrological interruption, or other means?	<input type="checkbox"/>	<input type="checkbox"/>	<input type="checkbox"/>	<input checked="" type="checkbox"/>
d) Interfere substantially with the movement of any native resident or migratory fish or wildlife species or with established native resident or migratory wildlife corridors, or impede the use of a native wildlife nursery site?	<input type="checkbox"/>	<input type="checkbox"/>	<input type="checkbox"/>	<input checked="" type="checkbox"/>
e) Conflict with any local policies or ordinances protecting biological resources, such as a tree preservation policy or ordinance?	<input type="checkbox"/>	<input type="checkbox"/>	<input type="checkbox"/>	<input checked="" type="checkbox"/>
f) Conflict with the provisions of an adopted Habitat Conservation Plan, Natural Community Conservation Plan, or other approved local, regional, or state habitat conservation plan?	<input type="checkbox"/>	<input type="checkbox"/>	<input type="checkbox"/>	<input checked="" type="checkbox"/>

## Responses:

The area where the dairy's located includes a large portion of western Madera County. The climate of this region is characterized by hot, dry summers and cool, wet winters. Urban areas are centered within the cities of Madera and Chowchilla, while the remaining portions of the area are characterized as agricultural lands. The San Joaquin River delineates the area boundary to the south and west, while the northern boundary is established by the Chowchilla River. The Fresno River and Chowchilla Canal are other major water bodies in the area.

The evaluation of biological resources includes a programmatic review of vegetation and wildlife habitat, special-status species, and wetland habitats that may meet the criteria for jurisdictional waters of the U.S. which occur or potentially occur in the area. The results of this programmatic evaluation are based upon literature searches and database queries of known and existing data.

**(a - f) No Impact.** No impacts have been identified as a result of this project. The digester project is being placed on an already existing dairy facility.

Special-status species are those plants and animals that, because of their recognized rarity or vulnerability to various causes of habitat loss or population decline, are recognized in some fashion by federal, state, or other agencies as deserving special consideration. Some of these species receive specific legal protection pursuant to federal or state endangered species legislation. Others lack such legal protection, but have been characterized as "sensitive" on the basis of adopted policies and expertise of state resource agencies or organizations with acknowledged expertise, or policies adopted by local governmental agencies such as counties, cities, and special districts to meet local conservation objectives.

While there are candidate species identified in the quadrangle in which this project is located, there has been no documentation of any of the species being located on or in the immediate vicinity of the project site. There is still the potential that some species may migrate through the vicinity. Given that there has been development on the site for some time, it is possible that there are no species in the area.

Vernal pools are temporary pools of water that provide habitats. They are considered to be a distinctive type of wetland usually devoid of fish, and thus allow the safe development of natal amphibian and insect species. Most vernal pools are dry for at least part of the year.

There are no indications of vernal pools present on the project site. And in consideration of the location of the project footprint, and the size of the footprint, the chances of impact on vernal pools is insignificant.

While the list below shows a number of species listed in the quadrangle in which this project is located, this does not necessarily mean that these species are actually located on the project site either in a habitat setting or migrating through. According to the biological survey, some examples include the Rawson's flaming trumpet which was noted as being approximately 0.95 of a mile southeast of the project site. The orange lupine was noted as being about 1.4 miles to the southwest of the project site. The CNDB only lists species in the quadrangle where the project is located, but this never is an indication of whether these species are or ever were on the project site.

Special Status Species is a general term that refers to all taxa tracked by the California Department of Fish and Wildlife's (CDFW) California Natural Diversity Database (CNDDDB), the USFWS IPac, and the CNPS (Resource Agencies), regardless of their legal or protection status. Special Status Species include:

- Plants and animals that are legally protected or proposed for protection under the California Endangered Species Act (CESA) or Federal Endangered Species Act (FESA);
- Plants and animals defined as endangered or rare under the California Environmental Quality Act (CEQA) §15380;
- Animals designated as species of special concern by the U.S. Fish and Wildlife Service (USFWS) or California Department of Fish and Game (CDFG);
- Animals listed as "fully protected" in the Fish and Game Code of California (§3511, §4700, §5050 and §5515); and
- Plants listed in the California Native Plant Society's (CNPS) Inventory of Rare and Endangered Vascular Plants of California.

A review of the Department of Fish and Wildlife's databases for special status species has identified the following species:

Species	Federal Listing	State Listing	Dept. of Fish and Game Listing	CNPS Listing
Swainson's Hawk	None	Threatened	None	None
Mountain plover	None	None	SSC	None
Tricolored Blackbird	None	Candidate Threatened	SSC	None
Vernal Pool Fairy Shrimp	Threatened	None	None	None
San Joaquin Kit Fox	Endangered	Threatened	None	None
American Badger	None	None	SSC	None
Blunt Nosed Leopard Lizard	Endangered	Endangered	FP	None
Coast Horned Lizard	None	None	SSC	None
Valley Sacaton Grassland	None	None	None	None
Valley Sink Scrub	None	None	None	None
Heatscale	None	None	None	1B.2
Shining Navarrelia	None	None	None	1B.2

### **Firebaugh NE Quadrangle**

List 1A: Plants presumed extinct

List 1B: Plants Rare, Threatened, or Endangered in California and elsewhere.

List 2: Plants Rare, Threatened, or Endangered in California, but more numerous elsewhere

List 3: Plants which more information is needed – a review list

List 4: Plants of Limited Distributed - a watch list

### **Ranking**

0.1 – Seriously threatened in California (high degree/immediacy of threat)

0.2 – Fairly threatened in California (moderate degree/immediacy of threat)

0.3 – Not very threatened in California (low degree/immediacy of threats or no current threats known)

SSC Species of Special Concern

WL Watch List

Movement corridors are characterized by the regular movements of one or more species through relatively well defined landscape features. They are typically associated with ridgelines, wetland complexes, and well-developed riparian habitats.

The area surrounding the parcel site has been developed for residential and agricultural purposes, so the chances of habitats being present for nesting or migratory species are minimal. During the construction of the facilities on site there is the potential of minimally impacting the migration patterns of listed species. This is due to noise production during the process of construction, which animals will instinctively avoid. This will be a temporary occurrence for the duration of the construction. Any disruption will be minimal as a result and will return to baseline levels at conclusion of the project construction. Operations of the facilities will have negligible impacts.

### **General Information**

Effective January 1, 2007, Senate Bill 1535 took effect that has changed de minimis findings procedures. The Senate Bill takes the de minimis findings capabilities out of the Lead Agency hands and puts the process into the hands of the California Department of Fish and Wildlife (formally the California Department of Fish and Game). A Notice of Determination filing fee is due each time a NOD is filed at the jurisdiction's Clerk's Office. The authority comes under Senate Bill 1535 (SB 1535) and Department of Fish and Wildlife Code 711.4. Each year the fee is evaluated and has the potential of increasing. For the most up-to-date fees, please refer to: [http://www.dfg.ca.gov/habcon/ceqa/ceqa\\_changes.html](http://www.dfg.ca.gov/habcon/ceqa/ceqa_changes.html).

The Valley Elderberry Longhorn Beetle (VELB) was listed as a threatened species in 1980. Use of the elderberry bush by the beetle, a wood borer, is rarely apparent. Frequently, the only exterior evidence of the elderberry's use by the beetle is an exit hole created by the larva just prior to the pupal stage. According to the USFWS, the Valley Elderberry Longhorn Beetle habitat is primarily in communities of clustered Elderberry plants located within riparian habitat. The USFWS stated that VELB habitat does not include every Elderberry plant in the Central Valley, such as isolated, individual plants, plants with stems that are less than one inch in basal diameter or plants located in upland habitat.

**V. CULTURAL RESOURCES**

Would the project:

	Potentially Significant Impact	Less Than Significant With Mitigation Incorporation	Less Than Significant Impact	No Impact
a) Cause a substantial adverse change in the significance of a historical resource pursuant to §15064.5?	<input type="checkbox"/>	<input type="checkbox"/>	<input checked="" type="checkbox"/>	<input type="checkbox"/>
b) Cause a substantial adverse change in the significance of an archaeological resource pursuant to §15064.5?	<input type="checkbox"/>	<input type="checkbox"/>	<input checked="" type="checkbox"/>	<input type="checkbox"/>
c) Disturb any human remains, including those interred outside of formal cemeteries?	<input type="checkbox"/>	<input type="checkbox"/>	<input checked="" type="checkbox"/>	<input type="checkbox"/>

**Responses:**

Cultural resources can be defined as buildings, sites, structures, objects, or places of importance that may have historical, architectural, archaeological, cultural, or scientific importance (including those associated with Native Americans or Native American activities). Preservation of the County’s unique cultural heritage should be considered when planning for future development of the area.

The western area of the County was originally inhabited by the Northern Valley Yokuts. Ethnographic information about this group is sparse due to the early dissemination of the aboriginal populations in the lower San Joaquin Valley.

The Northern Valley Yokuts territory is defined roughly by the crest of the Diablo Range on the west, and the foothills of the Sierra Nevada on the east. The southern boundary is approximately where the San Joaquin River bends northwards, and the northern boundary is roughly half way between the Calaveras and Mokelumne Rivers.

Principle settlements were located on the tops of low mounds, on or near the banks of larger watercourses. Settlements were composed of single family dwellings, sweathouses, and ceremonial assembly chambers. Dwellings were small and lightly constructed, semi-subterranean and oval. The public structures were large and earth covered.

With the development of Spanish Ranchos throughout California, cattle husbandry was prevalent, while dairy farms remained crude and sparse.

**(a – c) Less Than Significant Impact.** The dairies have been in operation for countless years at this point, so the likelihood of finding cultural or archaeological evidence is slim. However, ground disturbing activities could uncover previously unknown finds.

Most of the archaeological survey work in the County has taken place in the foothills and mountains. This does not mean, however, that no sites exist in the western part of the County, but rather that this area has not been as thoroughly studied. There are slightly more than 2,000 recorded archaeological sites in the county, most of which are located in the foothills and mountains. Recorded prehistoric artifacts include village sites, camp sites, bedrock milling stations, pictographs, petroglyphs, rock rings, sacred sites, and resource gathering areas. Madera County also contains a significant number of potentially historic sites, including homesteads and ranches, mining and logging sites and associated features (such as small camps, railroad beds, logging chutes, and trash dumps).

Public Resource Code 5021.1(b) defines a historic resource as "any object building, structure, site, area or place which is historically significant in the architectural, engineering, scientific, economic, agricultural, educational, social, political, military, or cultural annals of California." These resources are of such import, that it is codified in CEQA (PRC Section 21000) which prohibits actions that "disrupt, or adversely affect a prehistoric or historic archaeological site or a property of historical or cultural significance to a community or ethnic or social groups; or a paleontological site except as part of a scientific study."

Archaeological importance is generally, although not exclusively, a measure of the archaeological research value of a site which meets one or more of the following criteria:

- Is associated with an event or person of recognized significance in California or American history or of recognized scientific importance in prehistory.
- Can provide information which is both of demonstrable public interest and useful in addressing scientifically consequential and reasonable archaeological research questions.
- Has a special or particular quality such as oldest, best example, largest, or last surviving example of its kind.
- Is at least 100 years old and possesses substantial stratigraphic integrity (i.e. it is essentially undisturbed and intact).
- Involves important research questions that historic research has shown can be answered only with archaeological methods.

Potentially Significant Impact	Less Than Significant With Mitigation Incorporation	Less Than Significant Impact	No Impact
--------------------------------	---	------------------------------	-----------

**VI. ENERGY**

Would the project:

- |   |                          |                          |                          |                                     |
|---|--------------------------|--------------------------|--------------------------|-------------------------------------|
| a) Result in potentially significant environmental impact due to wasteful, inefficient, or unnecessary consumption of energy resources, during project construction or operation? | <input type="checkbox"/> | <input type="checkbox"/> | <input type="checkbox"/> | <input checked="" type="checkbox"/> |
| b) Conflict with or obstruct a state or local plan for renewable energy or energy efficiency?   | <input type="checkbox"/> | <input type="checkbox"/> | <input type="checkbox"/> | <input checked="" type="checkbox"/> |

**Responses:**

**(a & b) No Impact.** No impacts identified as a result of this project.

For the operational portion of the project, no vehicle trips will be generated. During the construction period of the project, there will be ongoing trip generation. This will be temporary in nature for the duration of the construction phase of the project. The length of these trips and the individual vehicle fuel efficiencies are not known; therefore the resulting energy consumption cannot be accurately calculated. Adopted federal vehicle fuel standards have continually improved since their original adoption in 1975 and assists in avoiding the inefficient, wasteful and unnecessary use of energy by vehicles.

As designed, this project is considered a renewable energy project due to the nature of the proposal.

\_\_\_\_\_



**VII. GEOLOGY AND SOILS**

Would the project:

a) Directly or indirectly cause potential substantial adverse effects, including the risk of loss, injury, or death involving:

i) Rupture of a known earthquake fault, as delineated on the most recent Alquist-Priolo Earthquake Fault Zone Map issued by the State Geologist for the area, or based on other substantial evidence of a known fault? Refer to Division of Mines and Geology Special Publication 42.

ii) Strong seismic ground shaking?

iii) Seismic-related ground failure, including liquefaction?

iv) Landslides?

b) Result in substantial soil erosion or the loss of topsoil?

c) Be located on a geological unit or soil that is unstable, or that would become unstable as a result of the project, and potentially result in on- or off-site landslide, lateral spreading, subsidence, liquefaction or collapse?

d) Be located on expansive soil, as defined in Table 18-1-B of the Uniform Building Code (1994), creating substantial direct or indirect risks to life or property?

e) Have soils incapable of adequately supporting the use of septic tanks or alternative wastewater disposal systems where sewers are not available for the disposal of wastewater?

f) Directly or indirectly destroy a unique paleontological resource or site or unique geologic feature?

Potentially Significant Impact	Less Than Significant With Mitigation Incorporation	Less Than Significant Impact	No Impact
--------------------------------	---	------------------------------	-----------

<input type="checkbox"/>	<input type="checkbox"/>	<input checked="" type="checkbox"/>	<input type="checkbox"/>
<input type="checkbox"/>	<input type="checkbox"/>	<input checked="" type="checkbox"/>	<input type="checkbox"/>
<input type="checkbox"/>	<input type="checkbox"/>	<input checked="" type="checkbox"/>	<input type="checkbox"/>
<input type="checkbox"/>	<input type="checkbox"/>	<input checked="" type="checkbox"/>	<input type="checkbox"/>
<input type="checkbox"/>	<input type="checkbox"/>	<input type="checkbox"/>	<input checked="" type="checkbox"/>
<input type="checkbox"/>	<input type="checkbox"/>	<input type="checkbox"/>	<input checked="" type="checkbox"/>
<input type="checkbox"/>	<input type="checkbox"/>	<input type="checkbox"/>	<input checked="" type="checkbox"/>
<input type="checkbox"/>	<input type="checkbox"/>	<input type="checkbox"/>	<input checked="" type="checkbox"/>

## Responses:

The regional geology of the area is influenced by the Great Valley, a topographically dominant northwest-trending valley approximately 50 miles wide and 400 miles long that formed between the Coast Range Mountains to the west and the Sierra Nevada Mountains to the east. The Great Valley itself is divided into northern and southern portions, named the Sacramento and San Joaquin Valleys respectively. The western portion of the county, which consists of the rich alluvial bottom lands of the San Joaquin Valley, is predominately agricultural. Most of the County's agricultural activities occur here, due to the level topography, prime cultivable soils, and excellent drainage.

Soils in the western (or valley) portion of Madera County can generally be placed in one of three major groups: recent alluvial fans and flood plains, the basin area, and older alluvial fans and terraces. The recent alluvial fans are gently sloping cone-shaped features located primarily along the Chowchilla, Fresno and San Joaquin Rivers. Flood plain soils along the San Joaquin River resulted primarily from flood events now largely controlled by Friant Dam. The basin area is located in the western portion of the valley and is nearly level. The area contains fine soil carried beyond the alluvial fans and deposited in the slower water of the flatlands. The older alluvial fans and terraces are areas that no longer receive flood deposits and have been subject to erosion and weathering in the time since their deposition.

**(a i - iv) Less than Significant Impact.** Madera County is divided into two major physiographic and geologic provinces: the Sierra Nevada Range and the Central Valley. The Sierra Nevada physiographic province in the northeastern portion of the county is underlain by metamorphic and igneous rock. It consists mainly of homogenous types of granitic rocks, with several islands of older metamorphic rock. The central and western parts of the county are part of the Central Valley province, underlain by marine and non-marine sedimentary rocks.

The foothill area of the County is essentially a transition zone, containing old alluvial soils that have been dissected by the west-flowing rivers and streams which carry runoff from the Sierra Nevadas.

Seismicity varies greatly between the two major geologic provinces represented in Madera County. The Central Valley is an area of relatively low tectonic activity bordered by mountain ranges on either side. The Sierra Nevada's, partly within Madera County, are the result of movement of tectonic plates which resulted in the creation of the mountain range. The Coast Ranges on the west side of the Central Valley are also a result of these forces, and continued movement of the Pacific and North American tectonic plates continues to elevate the ranges. Most of the seismic hazards in Madera County result from movement along faults associated with the creation of these ranges.

There are no active or potentially active faults of major historic significance within Madera County. The County does not lie within any Alquist Priolo Special Studies Zone for surface faulting or fault creep.

However, there are two significant faults within the larger region that have been and will continue to be, the principle sources of potential seismic activity within Madera County.

San Andreas Fault: The San Andreas Fault lies approximately 45 miles west of the county line. The fault has a long history of activity and is thus a concern in determining activity in the area.

Owens Valley Fault Group: The Owens Valley Fault Group is a complex system containing both active and potentially active faults on the eastern base of the Sierra Nevada Range. This group is located approximately 80 miles east of the County line in Inyo County. This system has historically been the source of seismic activity within the County.

The *Draft Environmental Impact Report* for the state prison project near Fairmead identified faults within a 100 mile radius of the project site. Since Fairmead is centrally located along Highway 99 within the county, this information provides a good indicator of the potential seismic activity which might be felt within the County. Fifteen active faults (including the San Andreas and Owens Valley Fault Group) were identified in the *Preliminary Geotechnical Investigation*. Four of the faults lie along the eastern portion of the Sierra Nevada Range, approximately 75 miles to the northeast of Fairmead. These are the Parker Lake, Hartley Springs, Hilton Creek and Mono Valley Faults. The remaining faults are in the western portion of the San Joaquin Valley, as well as within the Coast Range, approximately 47 miles west of Fairmead. Most of the remaining 11 faults are associated with the San Andreas, Calaveras, Hayward and Rinconada Fault Systems which collectively form the tectonic plate boundary of the Central Valley.

In addition, the Clovis Fault, although not having any historic evidence of activity, is considered to be active within quaternary time (within the past two million years), is considered potentially active. This fault line lies approximately six miles south of the Madera County line in Fresno County. Activity along this fault could potentially generate more seismic activity in Madera County than the San Andreas or Owens Valley fault systems. However, because of the lack of historic activity along the Clovis Fault, there is inadequate evidence for assessing maximum earthquake impacts.

Seismic ground shaking, however, is the primary seismic hazard in Madera County because of the County's seismic setting and its record of historical activity (General Plan Background Element and Program EIR). The project represents no specific threat or hazard from seismic ground shaking, and all new construction will comply with current local and state building codes. Other geologic hazards, such as landslides, lateral spreading, subsidence, and liquefaction have not been known to occur within Madera County.

According to the Madera County General Plan Background Report, groundshaking is the primary seismic hazard in Madera County. The valley portion of Madera County is located on alluvium deposits, which tend to experience greater groundshaking intensities than areas located on hard rock. Therefore, structures located in the valley will tend to suffer greater damage from groundshaking than those located in the foothill and mountain areas.

Liquefaction is a process whereby soil is temporarily transformed to a fluid form during intense and prolonged ground shaking. According to the Madera County General Plan Background Report, although there are areas of Madera County where the water table is at 30 feet or less below the surface, soil types in the area are not conducive to liquefaction because they are either too coarse in texture or too high in clay content; the soil types mitigate against the potential for liquefaction.

The Madera County Dairy Standards EIR indicates that the potential for liquefaction or other seismically-induced ground failure is low due to the lack of saturated near-surface granular sediments and the gentle topography in the western portion of the County where the majority of dairies exist. Furthermore, the seismic ground shaking expected during an earthquake in Madera County would probably not be severe enough to trigger large liquefaction-related ground failures. Some engineered and non-engineered earthen structures may experience localized ground failures. However, the severity of such a failure, considering the relatively low magnitude of the seismic event, would be minor, possibly resulting in some reparable damage.

The area is topographically flat, so landslides are not likely.

**(b) Less Than Significant Impact.** The parcel is subject to potential erosion due to rain events. This is primarily due to structures and impervious footprints of structures diverting rainwater to areas that once weren't so impacted. This will be minimal in light of the whole.

**(c - f) No impact.** There are no known impacts that will occur as a direct or indirect result of this project.

\_\_\_\_\_

	Potentially Significant Impact	Less Than Significant With Mitigation Incorporation	Less Than Significant Impact	No Impact
<b>VIII. GREENHOUSE GAS EMISSIONS</b>				
Would the project:				
a) Generate greenhouse gas emissions, either directly or indirectly, that may have a significant impact on the environment?	<input type="checkbox"/>	<input type="checkbox"/>	<input checked="" type="checkbox"/>	<input type="checkbox"/>
b) Conflict with an applicable plan, policy or regulation adopted for the purpose of reducing the emissions of greenhouse gases?	<input type="checkbox"/>	<input type="checkbox"/>	<input checked="" type="checkbox"/>	<input type="checkbox"/>

**Responses:**

The primary factors that determine air quality are the locations of air pollutant sources and the amounts of pollutants emitted. Meteorological and topographical conditions, however, also are important. Factors such as wind speed and direction, and air temperature gradients interact with physical landscape features to determine the movement and dispersal of criteria air pollutants.

The area where the majority of dairies within Madera County lies within the San Joaquin Valley Air Basin (SJVAB), basically a flat area bordered on the east by the Sierra Nevada Mountains; on the west by the Coast Ranges; and to the south by the Tehachapi Mountains. Airflow in the SJVAB is primarily influenced by marine air that enters through the Carquinez Straits where the San Joaquin-Sacramento Delta empties into the San Francisco Bay. The region's topographic features restrict air movement through and out of the basin. As a result, the SJVAB is highly susceptible to pollutant accumulation over time. Frequent transport of pollutants into the SJVAB from upwind sources also contributes to poor air quality.

Wind speed and direction play an important role in dispersion and transport of air pollutants. During summer periods, winds usually originate from the north end of the San Joaquin Valley and flows in a south-southeasterly direction through the valley, through the Tehachapi pass and into the neighboring Southeast Desert Air Basin. During winter months, winds occasionally originate from the south end of the valley and flow in a north-northwesterly direction. Also, during winter months, the valley experiences light, variable winds, less than 10 miles per hour (mph). Low wind speeds, combined with low inversion layers in the winter, create a climate conducive to high concentrations of certain air pollutants.

The SJVAB has an inland Mediterranean climate that is characterized by warm, dry summers and cooler winters. Summer high temperatures often exceed 100 degrees Fahrenheit, averaging from the low 90s in the northern part of the valley to the high 90s in the south. The daily summer temperature variation can be as high as 30 degrees Fahrenheit. Winters are for the most part mild and humid. Average high temperatures during the winter are in the 50s, while the average daily low temperature is in the 40s.

The vertical dispersion of air pollutants in the valley is limited by the presence of persistent temperature inversions. Air temperatures usually decrease with an increase in altitude. A reversal of this atmospheric state, where the air temperature increases with height, is termed an inversion. Air above and below an inversion does not mix because differences in air density restrict air pollutant dispersal.

Dairy manure digester and co-digester products can generate usable methane, a renewable energy resource, and also reduce greenhouse gas emissions. The Central Valley is home to approximately 1,400 dairies with about 1.6 million cows. Dairy digesters will directly advance California's major environmental goals of reducing GHG emissions and generating biogas to meet the State's Renewable Portfolio Standard goals.

Gases that trap heat in the atmosphere are called greenhouse gases. Carbon dioxide and methane are greenhouse gases that would result from dairies. Carbon dioxide is the first-most significant greenhouse gas that contributes to the concept of global warming, followed by methane. Carbon dioxide is generated by all material combustion and would be associated with dairies through the operation of trucks, mobile equipment and automobiles. Methane is emitted into the environment from various sources, including ruminant livestock and manure decomposition. Methane generation from ruminant animals is influenced by feed quality, essential nutrients in the feed, feeding level and schedule, and animal

health. Although not a criteria pollutant, ammonia is a Toxic Air Contaminant (TAC) and is considered a precursor to  $PM_{2.5}$ . Ammonia is generated during anaerobic decomposition of manure and is therefore of interest in evaluating the air quality impacts related to dairies.

While carbon dioxide and methane are considered greenhouse gases and are generated at dairies through decomposition of manure, the process of the dairy digesters captures these gases in significantly more quantities than if were to be left in lagoons.

Gases from the decomposition of manure is not commonly thought of as a hazardous waste or material in the traditional definitions. However, they do have the potential of causing serious health issues in large enough quantities and in enclosed facilities. Fatal or serious inhalation hazards of gases including hydrogen sulfide ( $H_2S$ ), carbon dioxide ( $CO_2$ ), methane ( $CH_4$ ), and ammonia ( $NH_3$ ) may exist where manure gases are generated through the handling of liquid or semi-solid manure through activities such as pumping, mixing, agitating, spreading, or cleaning-out. Oxygen deficiencies are an additional related concern.

A part of the project consists of going through a conditioning process that will remove  $H_2S$  (hydrogen sulfide – the “rotten egg” odor). Hydrogen sulfide is often produced by microbial breakdown in the absence of oxygen gas. This process is commonly known as anaerobic digestion. Once the  $H_2S$  has been removed, the remaining biogas will be transported to the Bloom Fuel Cell Energy Server.

Methane is a fuel, but it's also a potent greenhouse gas. Digestion can reduce the impact to climate change by capturing methane produced from manure that would otherwise be lost to the atmosphere. The reduction to global warming potential occurs when the methane is converted to carbon dioxide when combusted; a molecule of carbon dioxide has a 28 times lower global warming potential than a molecule of methane. Greenhouse gas emissions from manure storage, handling and processing can be reduced by more than 50% when integrating an anaerobic digester. This reduction is mostly a result of the digestate emitting less methane during storage after digestion when compared to undigested manure.

**(a - b) Less than Significant Impact.** While dairies are seen as potential emission sources for methane production, this project as designed will reduce the amount of methane production considerably. Digesters are designed to capture the off gassing of decomposing manure and transfer it to a production setup that then through its' process create energy that (in this case) is sold to the grid.

Greenhouse Gas (GHG) Emissions: The potential effect of greenhouse gas emission on global climate change is an emerging issue that warrants discussion under CEQA. Unlike the pollutants discussed previously that may have regional and local effects, greenhouse gases have the potential to cause global changes in the environment. In addition, greenhouse gas emissions do not directly produce a localized impact, but may cause an indirect impact if the local climate is adversely changed by its cumulative contribution to a change in global climate. Individual development projects contribute relatively small amounts of greenhouse gases that when added to other greenhouse gas producing activities around the world would result in an increase in these emissions that have led many to conclude is changing

the global climate. However, no threshold has been established for what would constitute a cumulatively considerable increase in greenhouse gases for individual development projects. The State of California has taken several actions that help to address potential global climate change impacts.

Assembly Bill 32 (AB 32), the California Global Warming Solutions Act of 2006, outlines goals for local agencies to follow in order to bring Greenhouse Gas (GHG) emissions to 1990 levels (a 25% overall reduction) by the year 2020. The California Air Resources Board (CARB) holds the responsibility of monitoring and reducing GHG emissions through regulations, market mechanisms and other actions. A Draft Scoping Plan was adopted by CARB in order to provide guidelines and policy for the State to follow in its steps to reduce GHG. According to CARB, the scoping plan's GHG reduction actions include: direct regulations, alternative compliance mechanisms, monetary and non-monetary incentives, voluntary actions, and market-based mechanisms such as a cap-and-trade system.

Following the adoption of AB 32, the California State Legislature adopted Senate Bill 375, which became the first major bill in the United States that would aim to limit climate change by linking directly to "smart growth" land use principles and transportation. It adds incentives for projects which intend to be in-fill, mixed use, affordable and self-contained developments. SB 375 includes the creation of a Sustainable Communities Strategy (SCS) through the local Metropolitan Planning Organizations (MPO) in order to create land use patterns which reduce overall emissions and vehicle miles traveled. Incentives include California Environmental Quality Act streamlining and possible exemptions for projects which fulfill specific criteria.

**IX. HAZARDS AND HAZARDOUS MATERIALS**

Would the project:

	Potentially Significant Impact	Less Than Significant With Mitigation Incorporation	Less Than Significant Impact	No Impact
a) Create a significant hazard to the public or the environment through the routine transport, use or disposal of hazardous materials?	<input type="checkbox"/>	<input type="checkbox"/>	<input type="checkbox"/>	<input checked="" type="checkbox"/>
b) Create a significant hazard to the public or the environment through reasonably foreseeable upset and accident conditions involving the release of hazardous materials into the environment?	<input type="checkbox"/>	<input type="checkbox"/>	<input type="checkbox"/>	<input checked="" type="checkbox"/>
c) Emit hazardous emissions or handle hazardous or acutely hazardous materials, substances, or waste within one-quarter mile of an existing or proposed school?	<input type="checkbox"/>	<input type="checkbox"/>	<input type="checkbox"/>	<input checked="" type="checkbox"/>
d) Be located on a site which is included on a list of hazardous materials sites compiled pursuant to Government Code Section 65962.5 and, as a result, would it create a significant hazard to the public or the environment?	<input type="checkbox"/>	<input type="checkbox"/>	<input type="checkbox"/>	<input checked="" type="checkbox"/>
e) For a project located within an airport land use plan or, where such a plan has not been adopted, within two miles of a public airport or public use airport, would the project result in a safety hazard or excessive noise for people residing or working in the project area?	<input type="checkbox"/>	<input type="checkbox"/>	<input type="checkbox"/>	<input checked="" type="checkbox"/>
f) Impair implementation of, or physically interfere with, an adopted emergency response plan or emergency evacuation plan?	<input type="checkbox"/>	<input type="checkbox"/>	<input type="checkbox"/>	<input checked="" type="checkbox"/>
g) Expose people or structures, either directly or indirectly, to a significant risk of loss, injury or death involving wildland fires?	<input type="checkbox"/>	<input type="checkbox"/>	<input type="checkbox"/>	<input checked="" type="checkbox"/>

**Responses:**

The western part of Madera County has historically experienced several concerns related to hazardous materials. The dominant land use in the area consists of existing dairies and irrigated agricultural crop production. Additional land uses include agricultural crop processing facilities, grain storage facilities and irrigation water supply canals and reservoirs.



A material is considered hazardous if it appears on a list of hazardous materials prepared by a federal, state, or local agency, or if it has characteristics defined as hazardous by such an agency. The California Code of Regulations (CCR) defines a hazardous material as a substance that, because of physical or chemical properties, quantity, concentration, or other characteristics, may either (1) cause an increase in mortality or an increase in serious, irreversible, or incapacitating illness; or (2) pose a substantial present or potential hazard to human health or environment when improperly treated, stored, transported or disposed of, or otherwise managed (CCR Title 22 Division 4.5 Chapter 10 Article 2 §66260.10).

Hazardous wastes are defined in the same manner. Hazardous wastes are hazardous materials that no longer have practical use, such as substances that have been discarded, discharged, spilled, contaminated or are being stored prior to proper disposal. Hazardous materials and hazardous wastes are classified according to four properties: toxicity, ignitability, corrosivity, and reactivity.

The use and management of chemicals, including hazardous materials, within the agricultural areas of the County are dominated by the application of fertilizer and pesticides for crop production. Hazardous materials management in agricultural areas also includes storage and use of hydrocarbon fuel. Diesel fuel is used to power mobile farm equipment (trucks, tractors, combines) and stationary equipment, including irrigation pumps and groundwater well pumps. Gasoline is stored at some dairy facilities. Other hazardous materials used at dairies can include chlorine and other disinfectants, oils and lubricants, and antifreeze.

The greatest wildland fire hazards exist in areas with quickly ignitable, dense understory vegetation, such as grasses, adjacent to slower and hotter burning fuels such as trees. These conditions exist in varying degrees over approximately two-thirds of Madera County, to the north and east of the Madera Canal.

Gases from the decomposition of manure is not commonly thought of as a hazardous waste or material in the traditional definitions. However, they do have the potential of causing serious health issues in large enough quantities and in enclosed facilities. Fatal or serious inhalation hazards of gases including hydrogen sulfide ( $H_2S$ ), carbon dioxide ( $CO_2$ ), methane ( $CH_4$ ), and ammonia ( $NH_3$ ) may exist where manure gases are generated through the handling of liquid or semi-solid manure through activities such as pumping, mixing, agitating, spreading, or cleaning-out. Oxygen deficiencies are an additional related concern. With the exception of the dairy digesters and the low pressure pipeline associated with the project, there are no enclosed spaces indicated for the project.

**(a - g) No Impact.** No impacts identified as a result of this project.

No chemicals or hazardous materials will be used as a result of the digesters. No dairy operations will change as a result of the project.

Any hazardous material because of its quantity, concentration, physical or chemical properties, pose a significant present or potential hazard to human health and safety, or the environment the California legislature adopted Article I, Chapter 6.95 of the Health and Safety Code, Sections 25500 to 25520 that requires any business handling or storing a hazardous material or hazardous waste to establish a Business Plan. The information obtained from the completed Business Plans will be provided to emergency response personnel for a better-prepared emergency response due to a release or threatened release of a hazardous material and/or hazardous waste.

Business owners that handle or store a hazardous material or mixtures containing a hazardous material, which has a quantity at any one time during the year, equal to or greater than:

- 1) A total of 55 gallons,
- 2) A total of 500 pounds,
- 3) 200 cubic feet at standard temperature and pressure of compressed gas,
- 4) Any quantity of Acutely Hazardous Material (AHM).

Assembly Bill AB 2286 requires all business and agencies to report their Hazardous Materials Business Plans to the Certified Unified Program Agency (CUPA) information electronically at <http://cers.calepa.ca.gov>

The site is not located on or near any hazardous waste storage facilities, or on or near any brownfields sites as indicated by the Environmental Protection Agency.

The project is not located anywhere near the Chowchilla or Madera airports or any known agricultural airstrips. The project parcel is not in an airport/airspace overlay zone. The project is located outside of the County's Airport Land Use Compatibility Zone.

The California Department of Forestry and Fire Protection (Cal-Fire) provides for protection services to most of Madera County. The stations within the vicinity include the facility located in Yosemite Lakes Park (Station #10), the station located next to the Coarsegold Community Center (Station #13), and facilities in O'Neals, and Ahwahnee.

County services such as fire suppression continue to remain inadequate and seriously underfunded. While not normally an environmental concern, new residential development in the foothills represents a heightened potential for fire risks, risks that the County does not have the resources to counter. While new development is required to maintain a fire safe area around each home site, little if any efforts are extended to the majority of large rural home sites to maintain a fire safe perimeter.

Residential construction has the potential of interfering with emergency response plans and evacuation plans with the increase in roads and gated sections typical of most subdivisions. New road systems could make it difficult for first responders who may not have updated maps of the area to find addresses for either medical or fire calls. This same feature (new roads) may inhibit residents from evacuating the area especially when there is a tremendous amount of smoke inhibiting visibility, as such situations typically induce panic in people.

**X. HYDROLOGY AND WATER QUALITY**

Would the project:

	Potentially Significant Impact	Less Than Significant With Mitigation Incorporation	Less Than Significant Impact	No Impact
a) Violate any water quality standards or waste discharge requirements or otherwise substantially degrade surface or groundwater quality?	<input type="checkbox"/>	<input type="checkbox"/>	<input type="checkbox"/>	<input checked="" type="checkbox"/>
b) Substantially decrease groundwater supplies or interfere substantially with groundwater recharge such that the project may impede sustainable groundwater management of the basin?	<input type="checkbox"/>	<input type="checkbox"/>	<input type="checkbox"/>	<input checked="" type="checkbox"/>
c) Substantially alter the existing drainage pattern of the site or area, including through the alteration of the course of a stream or river or through the addition of impervious surfaces, in a manner which would:				
(i) result in substantial erosion or siltation on- or off-site;	<input type="checkbox"/>	<input type="checkbox"/>	<input checked="" type="checkbox"/>	<input type="checkbox"/>
(ii) substantially increase the rate or amount of surface runoff in a manner which would result in flooding on- or offsite;	<input type="checkbox"/>	<input type="checkbox"/>	<input checked="" type="checkbox"/>	<input type="checkbox"/>
(iii) create or contribute runoff water which would exceed the capacity of existing or planned stormwater drainage systems or provide substantial additional sources of polluted runoff; or	<input type="checkbox"/>	<input type="checkbox"/>	<input checked="" type="checkbox"/>	<input type="checkbox"/>
(iv) impede or redirect flood flows?	<input type="checkbox"/>	<input type="checkbox"/>	<input checked="" type="checkbox"/>	<input type="checkbox"/>
d) In flood hazard, tsunami, or seiche zones, risk release of pollutants due to project inundation?	<input type="checkbox"/>	<input type="checkbox"/>	<input type="checkbox"/>	<input checked="" type="checkbox"/>
e) Conflict with or obstruct implementation of a water quality control plan or sustainable groundwater management plan?	<input type="checkbox"/>	<input type="checkbox"/>	<input type="checkbox"/>	<input checked="" type="checkbox"/>

## Responses:

**(a, b & d - e) No Impact.** No impacts identified as a result of this project.

A seiche is an occasional and sudden oscillation of the water of a lake, bay or estuary producing fluctuations in the water level and caused by wind, earthquakes or changes in barometric pressure. A tsunami (from the Japanese language, roughly translated as "harbor wave") is an unusually large sea wave produced by seaquake or undersea volcanic eruption. According to the California Division of Mines and Geology, there are no active or potentially active faults of major historic significance within Madera County. Additionally, there are no bodies of water (lakes, etc.) within proximity of the site. Madera County is geographically located in the center of the state, therefore not affected by tsunamis.

**(c) Less Than Significant Impact.** While there are no rivers or streams in the immediate vicinity of the project, having an additional non-porous surface (the pad where the equipment will be) has the potential of redirecting rainfall.

Rainfall is unable to percolate into paving that is expected to be on each site (building pad, driveways, structures, etc.) and is converted almost entirely into storm run-off, often exceeding the capacity of existing drainage system, causing intermittent flooding, increased flooding and other adverse impacts. It is possible that the quality of storm water may be affected by pollution such as, but not limited to, oil, grease, fuel, dissolved metals from batteries and glycols from automotive coolant or antifreeze. The applicant shall mitigate any impacts associated with storm water contamination caused by this project.

There is the potential of localized flooding that could occur in the vicinity of the project. This is dependent on rain fall, site features and drainage.

### **General Information**

Groundwater quality contaminants of concern in the Valley Floor include high salinity (total dissolved solids), nitrate, uranium, arsenic, methane gas, iron, manganese, slime production, and dibromochloropropane with the maximum contaminant level exceeded in some areas. Despite the water quality issues noted above, most of the groundwater in the Valley Floor is of suitable quality for irrigation. Groundwater of suitable quality for public consumption has been demonstrated to be present in most of the area at specific depths.

Groundwater quality contaminants of concern in the Foothills and Mountains include manganese, iron, high salinity, hydrogen sulfide gas, uranium, nitrate, arsenic, and methylbutylethylene (MTBE) with the maximum concentration level being exceeded in some areas. Despite these problems, there are substantial amounts of good-quality groundwater in each of the areas evaluated in the Foothills and Mountains. Iron and manganese are commonly removed by treatment. Uranium treatment is being conducted on a well by the Bass Lake Water Company.

A seiche is an occasional and sudden oscillation of the water of a lake, bay or estuary producing fluctuations in the water level and caused by wind, earthquakes or changes in barometric pressure. A tsunami (from the Japanese language, roughly translated as "harbor wave") is an unusually large sea wave produced by seaquake or undersea volcanic eruption. According to the California Division of Mines and Geology, there are no active or potentially active faults of major historic significance within Madera County. As this property is not located near any bodies of water, no impacts are identified.

The flood hazard areas of the County of Madera are subject to periodic inundation which results in loss of life and property, health and safety hazards, disruption of commerce and governmental services, extraordinary public expenditures for flood protection and relief, and impairment of the tax base, all of which adversely affect the public health, safety and general welfare. These flood losses are caused by uses that are inadequately elevated, floodproofed, or protected from flood damage. The cumulative effect of obstruction in areas of special flood hazards which increase flood height and velocities also contribute to flood loss.

\_\_\_\_\_

	Potentially Significant Impact	Less Than Significant With Mitigation Incorporation	Less Than Significant Impact	No Impact
<b>XI. LAND USE AND PLANNING</b>				
Would the project:				
a) Physically divide an established community?	<input type="checkbox"/>	<input type="checkbox"/>	<input type="checkbox"/>	<input checked="" type="checkbox"/>
b) Cause a significant environmental impact due to a conflict with any applicable land use plan, policy, or regulation adopted for the purpose of avoiding or mitigating an environmental effect?	<input type="checkbox"/>	<input type="checkbox"/>	<input type="checkbox"/>	<input checked="" type="checkbox"/>

**Responses:**

(a - c) **No Impact.** This project will not physically divide an existing community.

\_\_\_\_\_

Potentially Significant Impact	Less Than Significant With Mitigation Incorporation	Less Than Significant Impact	No Impact
--------------------------------	---	------------------------------	-----------

**XII. MINERAL RESOURCES**

Would the project:

- |   |                          |                          |                          |                                     |
|---|--------------------------|--------------------------|--------------------------|-------------------------------------|
| a) Result in the loss of availability of a known mineral resource that would be of value to the region and the residents of the state?                                | <input type="checkbox"/> | <input type="checkbox"/> | <input type="checkbox"/> | <input checked="" type="checkbox"/> |
| b) Result in the loss of availability of a locally-important mineral resource recovery site delineated on a local general plan, specific plan or other land use plan? | <input type="checkbox"/> | <input type="checkbox"/> | <input type="checkbox"/> | <input checked="" type="checkbox"/> |

**Responses:**

**(a - b) No Impact.** There are no known minerals in the vicinity of the project site.

Potentially Significant Impact	Less Than Significant With Mitigation Incorporation	Less Than Significant Impact	No Impact
--------------------------------	---	------------------------------	-----------

**XIII. NOISE**

Would the project result in:

- |   |                          |                          |                                     |                                     |
|---|--------------------------|--------------------------|-------------------------------------|-------------------------------------|
| a) Generation of a substantial temporary or permanent increase in ambient noise levels in the vicinity of the project in excess of standards established in the local general plan or noise ordinances, or applicable standards of other agencies?  | <input type="checkbox"/> | <input type="checkbox"/> | <input checked="" type="checkbox"/> | <input type="checkbox"/>            |
| b) Generation of excessive groundborne vibration or groundborne noise levels?   | <input type="checkbox"/> | <input type="checkbox"/> | <input checked="" type="checkbox"/> | <input type="checkbox"/>            |
| c) For a project located within the vicinity of a private airstrip or an airport land use plan or, where such a plan has not been adopted, within two miles of a public airport or public use airport, would the project expose people residing or working in the project area to excessive noise levels? | <input type="checkbox"/> | <input type="checkbox"/> | <input type="checkbox"/>            | <input checked="" type="checkbox"/> |

**Responses:**

The proposed project is located in an area of western Madera County, or more specifically, the area of the County considered most likely to accommodate future growth in dairy facilities. The noise sources associated with dairies are mainly dairy equipment, and vehicles operating on local roadways. Noise levels away from these noise sources can be quite low depending on the amount of nearby human activity.

**(a – b) Less than Significant Impact.** Construction activity noise levels would fluctuate depending on the particular type, number and duration of uses of various pieces of equipment used to construct any particular project on dairies. Construction-related material haul trips would raise ambient noise levels along haul routes, depending on the number of haul trips made and the type of vehicles used.

The digesters in and of themselves operationally will not increase ambient noise levels in comparison to the existing dairy.

Regarding ground-borne vibration levels, the potential of the digesters increasing the impacts is minimal at best, and definitely not increase any impacts from the existing dairy.

**(c) No Impact.** No airports or private airstrips are in the vicinity of the project. The closest airport is the Madera airport, at approximately 7 ½ miles north-northeast of the project area.

### **General Discussion**

The Noise Element of the Madera County General Plan (Policy 7.A.5) provides that noise which will be created by new non-transportation noise sources shall be mitigated so as not to exceed the Noise Element noise level standards on lands designated for noise-sensitive uses. However, this policy does not apply to noise levels associated with agricultural operations. All the surrounding properties, while include some residential units, are designated and zoned for agricultural uses. This impact is therefore considered less than significant.

Construction noise typically occurs intermittently and varies depending upon the nature or phase of construction (e.g. demolition/land clearing, grading and excavation, erection). The United States Environmental Protection Agency has found that the average noise levels associated with construction activities typically range from approximately 76 dBA to 84 dBA Leq, with intermittent individual equipment noise levels ranging from approximately 75 dBA to more than 88 dBA for brief periods.

### **Short Term Noise**

Noise from localized point sources (such as construction sites) typically decreases by approximately 6 dBA with each doubling of distance from source to receptor. Given the noise attenuation rate and assuming no noise shielding from either natural or human-made features (e.g. trees, buildings, and fences), outdoor receptors within approximately 400 feet of construction site could experience maximum noise levels of greater than 70 dBA when onsite construction-related noise levels exceed approximately 89 dBA at the project site boundary. Construction activities that occur during the more noise-sensitive eighteen hours could result in increased levels of annoyance and sleep disruption for occupants of nearby existing residential dwellings. As a result, noise-generating construction activities would be considered to have a potentially significant short-term impact. However with implementation of mitigation measures, this impact would be considered less than significant.

Long Term Noise

Mechanical building equipment (e.g. heating, ventilation and air conditioning systems, and boilers), associated with the proposed structures, could generate noise levels of approximately 90 dBA at 3 feet from the source. However, such mechanical equipment systems are typically shielded from direct public exposure and usually housed on rooftops, within equipment rooms, or within exterior enclosures.

Landscape maintenance equipment, such as leaf blowers and gasoline powered mowers, could result in intermittent noise levels that range from approximately 80 to 100 dBA at 3 feet, respectively. Based on an equipment noise level of 100 dBA, landscape maintenance equipment (assuming a noise attenuation rate of 6 dBA per doubling of distance from the source) may result in exterior noise levels of approximately 75 dBA at 50 feet.

**MAXIMUM ALLOWABLE NOISE EXPOSURE FOR  
NON-TRANSPORTATION NOISE SOURCES\***

		Residential	Commercial	Industrial (L)	Industrial (H)	Agricultural
Residential	AM	50	60	55	60	60
	PM	45	55	50	55	55
Commercial	AM	60	60	60	65	60
	PM	55	55	55	60	55
Industrial (L)	AM	55	60	60	65	60
	PM	50	55	55	60	55
Industrial (H)	AM	60	65	65	70	65
	PM	55	60	60	65	60
Agricultural	AM	60	60	60	65	60
	PM	55	55	55	60	55

\*As determined at the property line of the receiving land use. When determining the effectiveness of noise mitigation measures, the standards may be applied on the receptor side of noise barriers at the property line.

AM = 7:00 AM to 10:00 PM

PM = 10:00 PM to 7:00 AM

L = Light

H = Heavy

Note: Each of the noise levels specified above shall be lowered by 5 dB for pure tone noises, noises consisting primarily of speech or music, or for recurring impulsive noises. These noise level standards do not apply to residential units established in conjunction with industrial or commercial uses (e.g. caretaker dwellings).



Vibration perception threshold: The minimum ground or structure-borne vibrational motion necessary to cause a normal person to be aware of the vibration by such direct means as, but not limited to, sensation by touch or visual observation of moving objects. The perception threshold shall be presumed to be a motion velocity of one-tenth (0.1) inches per second over the range of one to one hundred Hz.

Reaction of People and Damage to Buildings from Continuous Vibration Levels		
Velocity Level, PPV (in/sec)	Human Reaction	Effect on Buildings
0.006 to 0.019	Threshold of perception; possibility of intrusion	Damage of any type unlikely
0.08	Vibration readily perceptible	Recommended upper level of vibration to which ruins and ancient monuments should be subjected
0.10	Continuous vibration begins to annoy people	Virtually no risk of architectural damage to normal buildings
0.20	Vibration annoying to people in buildings	Risk of architectural damage to normal dwellings such as plastered walls or ceilings
0.4 to 0.6	Vibration considered unpleasant by people subjected to continuous vibrations	Architectural damage and possibly minor structural damage

Source: Whiffen and Leonard 1971

**XIV. POPULATION AND HOUSING**

Would the project:

a) Induce substantial unplanned population growth in an area, either directly (for example, by proposing new homes and business) or indirectly (for example, through extension of roads or other infrastructure)?

Potentially Significant Impact      Less Than Significant With Mitigation Incorporation      Less Than Significant Impact      No Impact

b) Displace substantial numbers of existing people or housing, necessitating the construction of replacement housing elsewhere?

**Responses:**

**(a - c) No Impact.** No impacts identified as a result of this project.

\_\_\_\_\_

**XV. PUBLIC SERVICES**

a) Would the project result in substantial adverse physical impacts associated with the provision of new or physically altered governmental facilities, need for new or physically altered governmental facilities, the construction of which could cause significant environmental impacts, in order to maintain acceptable service ratios, response times or other performance objectives for any of the public services:

Potentially Significant Impact	Less Than Significant With Mitigation Incorporation	Less Than Significant Impact	No Impact
--------------------------------	---	------------------------------	-----------

i) Fire protection?	<input type="checkbox"/>	<input type="checkbox"/>	<input type="checkbox"/>	<input checked="" type="checkbox"/>
ii) Police protection?	<input type="checkbox"/>	<input type="checkbox"/>	<input type="checkbox"/>	<input checked="" type="checkbox"/>
iii) Schools?	<input type="checkbox"/>	<input type="checkbox"/>	<input type="checkbox"/>	<input checked="" type="checkbox"/>
iv) Parks?	<input type="checkbox"/>	<input type="checkbox"/>	<input type="checkbox"/>	<input checked="" type="checkbox"/>
v) Other public facilities?	<input type="checkbox"/>	<input type="checkbox"/>	<input type="checkbox"/>	<input checked="" type="checkbox"/>

**Responses:**

County services such as fire and law enforcement continue to remain inadequate and seriously underfunded. While not normally an environmental concern, new residential development in the foothills represents a heightened potential for fire risks, risks that the County does not have the resources to counter. While this is not technically a residential development by the strict determination, given that RV Park Facilities are considered a type of housing in the Health & Safety code, it is still a concern.

**(a-i through v) No Impact.** While the area may be prone to wildfires, the project itself is not seen as an impact as a result of construction.

Madera County Fire Department provides fire protection services to all unincorporated areas of Madera County, which has an estimated 2000 population of 74,734 persons. MCFD provides fire protection services to unincorporated areas of the County. The Fire Department has 17 fire stations, a fleet of 56 apparatus and support vehicles; and 32 career fire suppression personnel and 175 paid call firefighters, and seven support personnel. The Fire Department responds to

structure fires, vehicle accidents, medical aide, or any other emergencies. Seven of Madera County's fire stations are staffed 24 hours a day by a full-time career fire captain or fire apparatus engineer, and five of these stations are augmented by paid call firefighters. The remaining 10 fire stations are staffed exclusively by paid call firefighters. Based on the estimated 2006 population the unincorporated portion of Madera County has a current fire protection personnel ratio of 2.52:1000 to the populations (2.52 full-time career and paid on-call personnel to 1000 residents).

The Madera County Fire Department exists through a contract between Madera County and CalFire (California Department of Forestry and Fire Prevention) and operates six stations for County responses in addition to the state-funded CALFIRE stations for state responsibility areas. Under an "Amador Plan" contract, the County also funds the wintertime staffing of four fire seasonal CALFIRE stations. In addition, there are ten paid-call (volunteer) fire companies that operate from their own stations. The administrative, training, purchasing, warehouse, and other functions of the Department operate through a single management team with County Fire Administration.

The California Department of Forestry and Fire Protection (CDF) provides for protection services to most of Madera County. There are CDF fire stations located within the vicinity of Oakhurst, staffed mostly by a volunteer personnel on a paid per call basis. Other stations in the area include facilities in Coarsegold, O'Neals, and Ahwahnee. There is a CDF (Cal-Fire) station just south and west of the site on the west side of Highway 41.

Crime and emergency response is provided by the Madera County Sheriff's Department. There will be an incidental need for law enforcement in the events of theft and vandalism on the project site.

County Sheriff's Department personnel are strapped for resources as well. With new development, the potential for criminal activity (including but not limited to: home burglaries, assaults, auto thefts) increases.

Currently, the Madera County's Sheriff's Department provides law enforcement and patrols in the planning area, operating from substations in Oakhurst on Road 425B and the Mountain Government Center in Bass Lake.

A Federal Bureau of Investigations 2009 study suggests that there is on average of 2.7 law enforcement officials per 1,000 population for all reporting counties. The number for cities had an average of 1.7 law enforcement officials per 1,000 population.

A project that adds homes and commercial buildings to a community typically increases the need for various municipal services, such as fire and police protection. As the Court of Appeal recently confirmed in *City of Hayward v. Board of Trustees*, that need, though, is not itself an "environmental impact" of the project that the California Environmental Quality Act ("CEQA") requires the project proponent to mitigate.

In *City of Hayward*, a state university prepared an environmental impact report ("EIR") evaluating the environmental effects of its proposed master plan for the expansion of its campus, including two specific building projects, one for student housing and one for a parking structure. It concluded that building out the master plan would result in significant effects on aesthetics, air quality, cultural resources, and traffic, notwithstanding implementation of all feasible mitigation. All other effects, including effects on public services, were found to be insignificant or fully mitigated. The EIR concluded that the increase in campus population would not result in a significant environmental effect regarding fire and emergency medical services provided by the city fire department. It explained that the increased population would call for the addition of 11 firefighters, roughly the equivalent of one fire company, in order to maintain an adequate service ratio of one staff person for 1,000 people and that the facilities to house the added staff would be achieved by adding a bay to an existing fire station or constructing a new fire station. Noting that construction of such facilities would be subject to review under CEQA, the EIR concluded that since construction of such facilities would affect only a small area (an acre or less) in an urban location, it would not cause significant environmental effects. Based on this analysis, the EIR concluded that no mitigation regarding fire protection services was required.

The City of Hayward, in which the campus is located, sued alleging that the university had failed to comply with CEQA. The city contended that the university first should have concluded that the project would have a significant effect on emergency response times and thus the health and safety of the community, owing to the nonexistence of the additional firefighters and facilities needed to serve the increased population, and then should have assessed possible measures to mitigate that effect, such as hiring additional firefighters and building facilities to house them. The trial court agreed, explaining that it is not the increased demand for fire protection services that must per se be evaluated as an environmental impact, but rather that the lack of adequate fire protection services resulting from the project would have adverse effects on people and property. The university appealed.

The Court of Appeal reversed. With respect to the contention that the campus population increase would delay emergency response times and that would have real effects on the spread of fire and the safety of people and property, the Court responded: "While this may be true, the obligation to provide adequate fire and emergency medical services is the responsibility of the city [under the California Constitution.] The need for additional fire protection services is not an *environmental* impact that CEQA requires a project proponent to mitigate." The Court noted that the EIR analyzes response times and their impact on public safety, "concludes that the project will cause response times to fall to an inadequate level and finds that 11 additional fire fighters will be required to maintain adequate service levels," and "sets forth measures needed to provide adequate emergency services and concludes . . . that those measures will not have a significant effect on the environment." In the Court's view, that sufficed. It explained: "Although there is undoubtedly a cost involved in the provision of additional emergency services, there is no authority upholding the city's view that CEQA shifts financial responsibility for the provision of adequate fire and emergency response services to the project sponsor. The city has a constitutional obligation to provide adequate fire protection services. Assuming the city continues to perform its obligations, there is no basis

to conclude that the project will cause a substantial adverse effect on human beings.”

The Court found the EIR adequate as well in all other respects, except one, its discussion of the project’s effects on two neighboring parks, and ordered a writ of mandate to issue accordingly.

The Court’s opinion may serve to help stem the practice of some agencies to use CEQA as a mechanism to help fund municipal services by treating projects’ needs for such services as environmental impacts and calling on project proponents to mitigate those impacts by paying for municipal services and facilities.

The building construction will be governed by the requisite Building, Life, Safety and Fire Codes applicable at the time of construction. The mitigation tied to this finding is written in such a manner as to leave open as to what year the applicable codes will be enforced at the time of construction. This will ensure that the most current codes are followed instead of being tied to outdated codes.

No impacts are anticipated as a result of this project as it does not relate to any educational programs, or increase the surrounding population. With the exception of an on-site manager, the facility will act more of a transient use type facility geared towards the tourism industry,

The area’s public schools are provided by Yosemite Union High School District and Bass Lake Elementary School District; each head-quartered in Oakhurst adjoining the Oak Creek Intermediate School. The high school has an approximate attendance of 1000 students from ninth to twelfth grade. A bond issue was passed to assist in the expansion of school facilities including, but not limited to: addition of new classrooms, new multi-use buildings, new performance arts building, parking and recreation facilities. The Oak Creek Intermediate school provides enrollment for grades 6-8 and has a student population of approximately 225, while Oakhurst Elementary serves grades K-6 and has a student population of approximately 400. Wassuma Elementary School in Ahwahnee provides k-8 facilities for approximately 360 students. The remainder of student enrollments for the area is in Mountain Home K-10, Bass Lake K-5 and Wawona K-6 schools.

Most facilities within the district rely on portable classrooms to accommodate current enrollment with little or no reserve space. Both Yosemite Union High School District and Bass Lake Elementary School district report a trend towards declining enrollment. Long term forecasts for enrollment are not available.

The Madera County General Plan allocates three acres of park available land per 1,000 residents’ population.

Ambulance and paramedic service within the community is provided by Sierra Ambulance. Emergency medical care services are privately provided from commercial facilities in Oakhurst, and 12 hour emergency treatment is available at the medical clinic (an extension of Community Hospital in Fresno) at Highway 41 and Victoria Lane in Oakhurst. While 24 hour emergency treatment facilities have undergone trial operations, this service has not yet been proven to be financially feasible. A source or provider of permanent 24 hour emergency care has not been identified.

\_\_\_\_\_

	Potentially Significant Impact	Less Than Significant With Mitigation Incorporation	Less Than Significant Impact	No Impact
<b>XVI. RECREATION</b>				
a) Would the project increase the use of existing neighborhood and regional parks or other recreational facilities such that substantial physical deterioration of the facility would occur or be accelerated?	<input type="checkbox"/>	<input type="checkbox"/>	<input type="checkbox"/>	<input checked="" type="checkbox"/>
b) Does the project include recreational facilities or require the construction or expansion of recreational facilities which might have an adverse physical effect on the environment?	<input type="checkbox"/>	<input type="checkbox"/>	<input type="checkbox"/>	<input checked="" type="checkbox"/>

**Responses:**

**(a - b) No Impact.** No impacts as a result of this project.

\_\_\_\_\_

	Potentially Significant Impact	Less Than Significant With Mitigation Incorporation	Less Than Significant Impact	No Impact
--	--------------------------------------	--	------------------------------------	--------------

**XVII. TRANSPORTATION**

Would the project:

- |   |                          |                          |                          |                                     |
|---|--------------------------|--------------------------|--------------------------|-------------------------------------|
| a) Conflict with a program, plan, ordinance, or policy addressing the circulation system, including transit, roadway, bicycle and pedestrian facilities?        | <input type="checkbox"/> | <input type="checkbox"/> | <input type="checkbox"/> | <input checked="" type="checkbox"/> |
| b) Would the project conflict or be inconsistent with CEQA Guidelines section 15064.3, subdivision (b)?   | <input type="checkbox"/> | <input type="checkbox"/> | <input type="checkbox"/> | <input checked="" type="checkbox"/> |
| c) Substantially increase hazards due to a geometric design feature (e.g. sharp curves or dangerous intersections) or incompatible uses (e.g., farm equipment)? | <input type="checkbox"/> | <input type="checkbox"/> | <input type="checkbox"/> | <input checked="" type="checkbox"/> |
| d) Result in inadequate emergency access?   | <input type="checkbox"/> | <input type="checkbox"/> | <input type="checkbox"/> | <input checked="" type="checkbox"/> |

**Responses:**

Parts of four state highways pass the area of the County where the majority of the dairies exist.

State Route 99 (SR 99) is a four lane freeway that links the County with the entire State and is the eastern boundary of where most of the dairies are located. SR 99 is one of the most important corridors to the economic livelihood of the San Joaquin Valley because it serves as a main shipping line for agricultural products and other commercial goods. SR 99 is also the primary link to Interstate 5, connecting the Valley with Los Angeles and Sacramento metropolitan areas.

State Route 145 (SR 145) is a two- and four-lane highway extending north/south from the Fresno County line to the City of Madera, then east/west to its intersection with SR41, SR 145 provides secondary access to Yosemite National Park via SR 41, and provides an important link to both SR 99 and Interstate 5. It runs north/south through an eastern portion of the County where the majority of dairies exist, and is also a key shipping route for agricultural products.

State Route 152 (SR 152) is a four land divided expressway extending east and west from the Merced County Line to SR 99. SR 152 is a primary access route from the central San Joaquin Valley to Monterey and Santa Clara Counties. This state route is considered an important agricultural, commercial and recreational access route and runs east/west through the northern portion of where the dairies exist in the county.

State Route 233 (SR 233) is a two- and four-lane highway extending four miles northeasterly from its intersection with SR 152 to the interchange with SR 99. This route serves primarily to provide for northbound traffic movement from SR 152 and SR 99 as well as local access to Chowchilla.

In addition to the regional state routes, a variety of County maintained roadways pass through the area. These include Avenue 7, Avenue 14, Avenue 18 ½, Road 16 and Road 9.

As with most rural areas, Eastern Madera County is served by limited alternative transportation modes. Currently, only limited public transportation facilities or routes exist within the area. Volunteer systems such as the driver escort service, as well as the senior bus system, operate for special purpose activities and are administered by the Madera County Action Committee. The rural densities which are prevalent throughout the region have typically precluded successful public transit systems, which require more concentrated populations in order to gain sufficient ridership. Oakhurst is therefore dependent on private automobile and truck access.

Per the Madera County Dairy Standards EIR, each dairy site would be expected to have its own access to the adjacent local roadway. Therefore, each dairy's traffic will be well dispersed geographically, precluding concentrated traffic flows at any access point. All local roadways in the rural areas of the county are typically straight, two-laned roads in a relatively flat terrain. Overall, visibility and sight distances are considered good and most of the area is currently used for agricultural purposes.

**(a – d) No Impact.** No impacts identified as a result of this project.

In the area around the proposed project, opportunities for bicycles and pedestrians, especially as an alternative to the private automobile, are significantly limited by lack of developed shoulders, sidewalks or pavement width accommodating either mode. The condition is not uncommon in rural areas where distances between origins and destinations are long and the terrain is either rolling or mountainous. In the locations outside urbanized portions of the County, the number of non-recreational pedestrians/cyclists would likely be low, even if additional facilities were provided.

As with most rural areas, Madera County is served by limited alternative transportation modes. Currently, only limited public transportation facilities or routes exist within the area. Volunteer systems such as the driver escort service, as well as the senior bus system, operate for special purpose activities and are administered by the Madera County Action Committee. The rural densities which are prevalent throughout the region have typically precluded successful public transit systems, which require more concentrated populations in order to gain sufficient ridership.

Local circulation is largely deficient with these same State Highways and County Roads composing the only existing network of through streets. Most local streets are dead-end drives, many not conforming to current County improvement standards. Existing traffic, particularly during peak hour and key intersections, already exhibits congestion.



Madera County currently uses Level Of Service “D” as the threshold of significance level for roadway and intersection operations. The following charts show the significance of those levels.

Level of Service	Description	Average Control Delay (sec./car)
A	Little or no delay	0 – 10
B	Short traffic delay	>10 – 15
C	Medium traffic delay	> 15 – 25
D	Long traffic delay	> 25 – 35
E	Very long traffic delay	> 35 – 50
F	Excessive traffic delay	> 50

Unsignalized intersections.

Level of Service	Description	Average Control Delay (sec./car)
A	Uncongested operations, all queues clear in single cycle	< 10
B	Very light congestion, an occasional phase is fully utilized	>10 – 20
C	Light congestion; occasional queues on approach	> 20 – 35
D	Significant congestion on critical approaches, but intersection is functional. Vehicles required to wait through more than one cycle during short peaks. No long-standing queues formed.	> 35 – 55
E	Severe congestion with some long-standing queues on critical approaches. Traffic queues may block nearby intersection(s) upstream of critical approach(es)	> 55-80
F	Total breakdown, significant queuing	> 80

Signalized intersections.

Level of service	Freeways	Two-lane rural highway	Multi-lane rural highway	Expressway	Arterial	Collector
A	700	120	470	720	450	300
B	1,100	240	945	840	525	350
C	1,550	395	1,285	960	600	400
D	1,850	675	1,585	1,080	675	450
E	2,000	1,145	1,800	1,200	750	500

Capacity per hour per lane for various highway facilities

Madera County is predicted to experience significant population growth in the coming years (62.27 percent between 2008 and 2030). Accommodating this amount of growth presents a challenge for attaining and maintain air quality standards and for reducing greenhouse gas emissions. The increase in population is expected to be accompanied by a similar increase in vehicle miles traveled (VMT) (61.36 percent between 2008 and 2030).

Horizon Year	Total Population (thousands)	Employment (thousands)	Average Weekday VMT (millions)	Total Lane Miles
2010	175	49	5.4	2,157
2011	180	53	5.5	NA
2017	210	63	6.7	NA
2020	225	68	7.3	2,264
2030	281	85	8.8	2,277

Source: MCTC 2007 RTP

The above table displays the predicted increase in population and travel. The increase in the lane miles of roads that will serve the increase in VMT is estimated at 120 miles or 0.94 percent by 2030. This indicates that roadways in Madera County can be expected to become much more crowded than is currently experienced.

Emissions of CO (Carbon Monoxide) are the primarily mobile-source criteria pollutant of local concern. Local mobile-source CO emissions near roadway intersections are a direct function of traffic volume, speed and delay. Carbon monoxide transport is extremely limited; it disperses rapidly with distance from the source under normal meteorological conditions. Under certain meteorological conditions, however, CO concentrations close to congested roadway or intersection may reach unhealthy levels, affecting local sensitive receptors (residents, school children, hospital patients, the elderly, etc.). As a result, the SJVAPCP recommends analysis of CO emissions of at a local rather than regional level. Local CO concentrations at intersections projected to operate at level of service (LOS) D or better do not typically exceed national or state ambient air quality standards. In addition, non-signalized intersections located within areas having relatively low background concentrations do not typically have sufficient traffic volumes to warrant analysis of local CO concentrations.

Local circulation is largely deficient with these same State Highways and County Roads composing the only existing network of through streets. Most local streets are dead-end drives, many not conforming to current County improvement standards. Existing traffic, particularly during peak hour and key intersections, already exhibits congestion.

Local circulation improvement is needed to support state highways and county roads forming the majority of the existing network of through streets. Many local streets are dead-end drives (some of which do not conform to current County improvement standards). Emergency access is, therefore, an important issue for area residents.

Several natural barriers such as the Fresno River, numerous tributary creeks and rocky and steep mountain terrain have precluded or complicated a more complete network of regional or community circulation routes. Financial constraints in the past prevented the design and construction of transportation routes which serve the community as a whole rather than individual private development. New developments occurring within the county are required to provide adequate access in the form of local roads to serve development.

The maneuvering of project construction vehicles and equipment among general purpose vehicles on local roads could cause safety hazards. Haul trucks and other on-road vehicles to be used during project construction could increase the hazard risk on existing roadways. The traffic safety hazard risk could increase because of conflicts with construction vehicles entering a public right-of-way from a project worksite; conflicts where road width is narrowed or a roadway is closed during construction activities, which could result in delays to emergency vehicles passing through a project area; or increased traffic (necessitating slower speed and a wider turning radius) during construction.

In addition to these potential impacts, the use of large trucks to transport equipment and material to and from the worksite could affect road conditions on the access roads by increasing the rate of road wear.

Potentially Significant Impact	Less Than Significant With Mitigation Incorporation	Less Than Significant Impact	No Impact
--------------------------------------	--	------------------------------------	--------------

**XVIII. TRIBAL CULTURAL RESOURCES**

Would the project:

a) Would the project cause a substantial adverse change in the significance of a tribal cultural resource, defined in Public Resources Code Section 21074 as either a site, feature, place cultural landscape that is geographically defined in terms of the size and scope of the landscape, sacred place, or object with cultural value to a California Native American tribe, and that is:

- |     |   |                          |                          |                          |                                     |
|-----|---|--------------------------|--------------------------|--------------------------|-------------------------------------|
| i.  | Listed or eligible for listing in the California Register of Historical Resources, or in a local register of historical resources as defined in Public Resources Code Section 5020.1(k), or   | <input type="checkbox"/> | <input type="checkbox"/> | <input type="checkbox"/> | <input checked="" type="checkbox"/> |
| ii. | A resource determined by the lead agency, in its discretion and supported by substantial evidence, to be significant pursuant to criteria set forth in subdivision (c) of Public Resources Code Section 5024.1. In applying the criteria set forth in subdivision (c) of Public Resources Code Section 5024.1, the lead agency shall consider the significance of the resource to a California Native American tribe. | <input type="checkbox"/> | <input type="checkbox"/> | <input type="checkbox"/> | <input checked="" type="checkbox"/> |

**Responses:**

**(a) No Impact.** No impacts have been identified as a result of this project.

**XIX. UTILITIES AND SERVICE SYSTEMS**

Would the project:

	Potentially Significant Impact	Less Than Significant With Mitigation Incorporation	Less Than Significant Impact	No Impact
a) Require or result in the relocation or construction of new or expanded water, wastewater treatment, or stormwater drainage, electric power, natural gas, or telecommunications facilities, the construction or relocation of which could cause significant environmental effects?	<input type="checkbox"/>	<input type="checkbox"/>	<input type="checkbox"/>	<input checked="" type="checkbox"/>
b) Have sufficient water supplies available to serve the project and reasonably foreseeable future development during normal, dry and multiple dry years?	<input type="checkbox"/>	<input type="checkbox"/>	<input type="checkbox"/>	<input checked="" type="checkbox"/>
c) Result in a determination by the wastewater treatment provider which serves or may serve the project that it had adequate capacity to serve the project's projected demand in addition to the provider's existing commitments?	<input type="checkbox"/>	<input type="checkbox"/>	<input type="checkbox"/>	<input checked="" type="checkbox"/>
d) Generate solid waste in excess of State or local standards, or in excess of the capacity of local infrastructure, or otherwise impair the attainment of solid waste reduction goals?	<input type="checkbox"/>	<input type="checkbox"/>	<input type="checkbox"/>	<input checked="" type="checkbox"/>
e) Comply with federal, state, and local management and reduction statutes and regulations related to solid waste?	<input type="checkbox"/>	<input type="checkbox"/>	<input type="checkbox"/>	<input checked="" type="checkbox"/>

**Responses:**

Water Quality Issues

Erosion and sedimentation/siltation are two potentially significant impacts related to development with the entire Oakhurst area. These impacts are generally proportional to the intensity of development which occurs in an area, including the amount of the clearing and grading which is necessary.

Rainfall is unable to percolate into the portions of each site that are paved over and is converted almost entirely into storm run-off, often exceeding the capacity of existing drainage system, causing intermittent flooding, increased flooding and other adverse impacts. Pollutants associated with parking lots (oil & grease predominately) will be found in high quantities after the first rain of the season. These pollutants have the potential of contaminating ground and surface water sources.

### Groundwater availability issues

Groundwater within the area is generally limited and unpredictable as a result of geologic formation which characterizes the mountain and foothill regions of Madera County. These areas are generally underlain by impervious bedrock, and "groundwater" is available only through water bearing fractures within these formations. Within these "fracture" systems the ability to store and transmit water is solely dependent on the development of secondary openings such as faults, joints and exfoliation planes.

The Area Plans for Oakhurst and surrounding communities recognizes that the provision for water for both domestic use and fire protection is a determining factor in how the community grows and what uses can be established in the area. The area depends on wells for its water. No "water table" exists; the water is obtained from fractures in the underlying rock which are frequently unconnected. The recharge is unknown and there is evidence from abandoned wells in the region that some may never recharge. Hardrock wells are generally characterized by both unpredictable and unreliable yields and the presence of intermittent water quality issues. Regular reports are received of well interference or lowering of the water level (draw down) as new wells are drilled in the area. While little quantified data has historically been available to help determine the sustainability of groundwater usage in this hardrock environment, concerns regarding quality and quantity have led to increased community focus on the cumulative impacts of new development and the need to identify and secure a source of surface water.

Due to these concerns regarding the uncertainty of groundwater, the Area Plan outlines the need to both understand groundwater availability for the area, and to examine opportunities to develop a source of surface water for the community. Several potential surface water sources for the greater eastern Madera County area have been evaluated over the years. Planning documents for the area beginning in the early 1960's identified the potential for a "Soquel" reservoir above Oakhurst within the Sierra National Forest. Later concepts included purchasing surface rights and delivering water from Bass Lake or the Fresno River. Most recently, the potential to purchase and deliver water from Redinger Lake has been studied. The development and implementation of a plan for surface water source been hindered by the presence of existing commitments for all surface water in the area. Additionally, environmental clearances, technical requirements, and the costs associated with developing a surface water source are significant. Despite these hurdles, the Area Plan notes that a surface water source must be viewed as the long-term solution and includes as a policy the initiation of a study to examine opportunities for a surface water source. The following Area Plan policies are proposed to address issues related to the provision of water.

### Wastewater Issues

The reliance on septic systems has generated concerns regarding potential impacts to both surface and ground water quality, particularly where septic systems are concentrated on individual lots. This project will have an on-site treatment facility.

### Solid Waste Issues

According to the Madera County General Plan Background report, all solid waste generated in the unincorporated area is currently disposed of at the Fairmead Landfill, which is owned by the County and operated by Madera Disposal Systems, Inc. The landfill facility is located on 48 acres at the southeast corner of Road 19 and Avenue 22. The landfill is expected to reach capacity in 2020. If additional waste can be diverted, the life of the expansion area could be increased. There is the potential for approximately 28 residential units' total that would be in need of disposing of residential related waste material to this landfill. Recycling measures are strongly encouraged. According to the California Integrated Waste Management Board, the generation rate per resident is 0.63 pounds per day of trash.

**(a - e) No Impact.** No impacts have been identified as a result of this project.

### General Discussion

Madera County has 34 County Service Areas and Maintenance Districts that together operate 30 small water systems and 16 sewer systems. Fourteen of these special districts are located in the Valley Floor, and the remaining 20 special districts are in the Foothills and Mountains. MD-1 Hidden Lakes, Bass Lake (SA-2B and SA-2C) and SA-16 Sumner Hill have surface water treatment plants, with the remaining special districts relying solely on groundwater.

The major wastewater treatment plants in the County are operated in the incorporated cities of Madera and Chowchilla and the community of Oakhurst. These wastewater systems have been recently or are planned to be upgraded, increasing opportunities for use of recycled water. The cities of Madera and Chowchilla have adopted or are in the process of developing Urban Water Management Plans. Most of the irrigation and water districts have individual groundwater management plans. All of these agencies engage in some form of groundwater recharge and management.

Groundwater provides almost the entire urban and rural water use and about 75 percent of the agricultural water use in the Valley Floor. The remaining water demand is met with surface water. Almost all of the water use in the Foothills and Mountains is from groundwater with only three small water treatment plants relying on surface water from the San Joaquin River and its tributaries.

In areas of higher precipitation (Oakhurst, North Fork, and the topographically higher part of the Coarsegold Area), groundwater recharge is adequate for existing uses. However, some problems have been encountered in parts of these areas due to well interference and groundwater quality issues. In areas of lower precipitation (Raymond-Hensley Lake and the lower part of the Coarsegold area), groundwater recharge is more limited, possibly requiring additional water supply from other sources to support future development.

Madera County is served by a solid waste facility (landfill) in Fairmead. There is a transfer station in North Fork. The Fairmead facility also provides for Household Hazardous Materials collections on Saturdays. The unincorporated portion of the County is served by Red Rock Environmental Group. Above the 1000 foot elevation, residents are served by EMADCO services for solid waste pick-up.

---

	Potentially Significant Impact	Less Than Significant With Mitigation Incorporation	Less Than Significant Impact	No Impact
<b>XX. WILDFIRE</b>				
If located in or near state responsibility areas or lands classified as very high fire hazard severity zones, would the project:				
a) Substantially impair an adopted emergency response plan or emergency evacuation plan?	<input type="checkbox"/>	<input type="checkbox"/>	<input type="checkbox"/>	<input checked="" type="checkbox"/>
b) Due to slope, prevailing winds, and other factors, exacerbate wildfire risks, and thereby expose project occupants to, pollutant concentrations from a wildfire or the uncontrolled spread of a wildfire?	<input type="checkbox"/>	<input type="checkbox"/>	<input type="checkbox"/>	<input checked="" type="checkbox"/>
c) Require the installation or maintenance of associated infrastructure (such as roads, fuel breaks, emergency water sources, power lines or other utilities) that may exacerbate fire risk or that may result in temporary or ongoing impacts to the environment?	<input type="checkbox"/>	<input type="checkbox"/>	<input type="checkbox"/>	<input checked="" type="checkbox"/>
d) Expose people or structures to significant risks, including downslope or downstream flooding or landslides, as a result of runoff, post-fire slope instability, or drainage changes?	<input type="checkbox"/>	<input type="checkbox"/>	<input type="checkbox"/>	<input checked="" type="checkbox"/>

**Responses:**

**(a – d) No Impact.** No impacts identified as a result of this project.

---



**XIX. MANDATORY FINDINGS OF SIGNIFICANCE**

	Potentially Significant Impact	Less Than Significant With Mitigation Incorporation	Less Than Significant Impact	No Impact
a) Does the project have the potential to substantially degrade the quality of the environment, substantially reduce the habitat of a fish or wildlife species, cause a fish or wildlife population to drop below self-sustaining levels, threaten to eliminate a plant or animal community, substantially reduce the number or restrict the range of a rare or endangered plant or animal or eliminate important examples of the major periods of California history or prehistory?	<input type="checkbox"/>	<input type="checkbox"/>	<input checked="" type="checkbox"/>	<input type="checkbox"/>
b) Does the project have impacts that are individually limited, but cumulatively considerable? ("Cumulatively considerable" means that the incremental effects of a project are significant when viewed in connection with the effects of past projects, the effects of other current projects, and the effects of probable future projects.)	<input type="checkbox"/>	<input type="checkbox"/>	<input type="checkbox"/>	<input checked="" type="checkbox"/>
d) Does the project have environmental effects which will cause substantial adverse effects on human beings, either directly or indirectly?	<input type="checkbox"/>	<input type="checkbox"/>	<input type="checkbox"/>	<input checked="" type="checkbox"/>

**Responses:**

CEQA defines three types of impacts or effects:

- Direct impacts are caused by a project and occur at the same time and place (CEQA §15358(a)(1).
- Indirect or secondary impacts are reasonably foreseeable and are caused by a project but occur at a different time or place. They may include growth inducing effects and other effects related to changes in the pattern of land use, population density or growth rate and related effects on air, water and other natural systems, including ecosystems (CEQA §15358(a)(2).
- Cumulative impacts refer to two or more individual effects which, when considered together, are considerable or which compound or increase other environmental impacts (CEQA §15355(b)). Impacts from individual projects may be considered minor, but considered retroactively with other projects over a period of time, those impacts could be significant, especially where listed or sensitive species are involved.

**(a) Less than Significant Impact.** While there are some species of note in the quadrangle, there is no direct evidence that these species are exactly on the footprint of where this is going.

**(b - c) No Impact.** While there have been some minimal impacts identified through this study, none are considered significant in and of themselves, and/or cumulative inducing enough to be considered significant. With appropriate mitigations, those impacts can be reduced to less than significant or not significant.

---

### **Mitigation Measures**

See attached.

### **Bibliography**

California Department of Finance

California Department of Transportation (CALTRANS)

California Integrated Waste Management Board

California Environmental Quality Act Guidelines

United States Environmental Protection Agency

Caltrans website [http://www.dot.ca.gov/hq/LandArch/scenic\\_highways/index.htm](http://www.dot.ca.gov/hq/LandArch/scenic_highways/index.htm) accessed October 31, 2008

California Department of Fish and Wildlife "California Natural Diversity Database" <https://www.wildlife.ca.gov/Data/CNDDDB/Maps-and-Data#43018410-cnddb-quickview-tool>

Madera County Airport Land Use Compatibility Plan

Madera County Dairy Standards

Madera County Dairy Standards Environmental Impact Report

Madera County General Plan

Madera County Integrated Regional Water Management Plan

Madera County Department of Environmental Health

Madera County Fire Marshall's Office

Madera County Department of Public Works

Madera County Roads Department

State of California, Department of Finance, *E-5 Population and Housing Estimates for Cities, Counties, and the State, 2011 and 2012, with 2010 Benchmark*. Sacramento, California, May 2012

MND 2019-11

1

June 20, 2019

## MITIGATED NEGATIVE DECLARATION

MND

RE: CUP#2019-008 – South Point Dairy

LOCATION AND DESCRIPTION OF PROJECT:

The subject property is located on the north east and south west corner of Avenue 13 and Road 14, approximately 1.47 miles west of its' intersection with Road 16 (13668 Avenue 13), Madera

Madera County, California, is located in the central portion of California's Sacramento/San Joaquin Valley. Located in the center of the state, Madera County comprises 2,147 square miles. Elevations above mean sea level (msl) range from less than 180 feet msl in the western portion of the county to over 13,000 feet msl along the crest of the Sierra Nevada Mountains.

This is a request to amend CUP #2014-014 to allow the construction and operation of an anaerobic digester at South Point Dairy, an existing dairy facility, along with necessary infrastructure for wastewater management. Additionally, it is proposed to construct a low-pressure pipeline to deliver biogas to a proposed Bloom Fuel Cell Energy Server (separate CUP) to be constructed 1 ½ miles northwest along Avenue 14.

ENVIRONMENTAL IMPACT:

No adverse environmental impact is anticipated from this project. The following mitigation measures are included to avoid any potential impacts.

BASIS FOR NEGATIVE DECLARATION:

See attached



Madera County Environmental Committee

A copy of the negative declaration and all supporting documentation is available for review at the Madera County Planning Department, 200 West Fourth Street, Ste. #3100, Madera, California.

DATED: June 20, 2019

FILED:

PROJECT APPROVED:

# MITIGATION MONITORING REPORT

**MND # 2019-11**

No.	Mitigation Measure	Monitoring Phase	Enforcement Agency	Monitoring Agency	Action Indicating Compliance	Verification of Compliance		
						Initials	Date	Remarks
<b>Aesthetics</b>								
	Use low-glare lighting to minimize nighttime glare effects on neighboring parcels							
	Hood and direct away from neighboring parcels all lighting associated with this project							
<b>Agricultural Resources</b>								
<b>Air Quality</b>								
	No idling of vehicles related to construction or operations of facility for longer than 10 minutes.							
	All circulation areas, roads and parking areas to be constructed and maintained in a dust free manner							
	All disturbed areas, including storage piles, which are not being actively utilized for construction purposes, shall be effectively stabilized of dust emissions using water, chemical stabilizer/suppressants, covered with a tarp or other suitable cover or vegetative ground cover in order to comply with San Joaquin Valley Air Pollution Control District's regulations.							
	All land clearing, grubbing, scraping, excavation, land leveling, grading, cut and fill, and demolition activities shall be effectively controlled of fugitive dust emissions utilizing application of water or by presoaking.							
	Applicant shall implement San Joaquin Valley Air Pollution Control Regulation VIII regarding fugitive dust emissions during construction and operations activities.							
	Applicant shall implement all requirements of the SJVAPCD for ROG emissions.							
	Digesters and related equipment shall be maintained so as not to release any component of manure decomposition							

No.	Mitigation Measure	Monitoring Phase	Enforcement Agency	Monitoring Agency	Action Indicating Compliance	Verification of Compliance		
						Initials	Date	Remarks
<b>Biological Resources</b>								
	no construction near any rivers, streams or creeks							
<b>Cultural Resources</b>								
	If archeological evidence is noted on the site prior to the start of construction, no work shall start without first notifying the Planning Department and completion of a Phase 2 archaeological study.							
	If during the grading or trenching work archeological evidence is found, all work is to stop and the Planning Department is to be notified within 24 hours, or on the first work day following for weekends and holidays.							
	If project construction related activities (including, but not limited to ground disturbing activities) result in the disturbing of subsurface cultural deposits, project related activities shall be halted and a professional archaeologist brought in to determine the culture of the deposits. In addition, if human remains are unearthed, the Madera County Coroner must be notified immediately.							
<b>Geology and Soils</b>								
<b>Hazards and Hazardous Materials</b>								
	No hazardous material or hazardous waste as it relates to the mini storage shall not be stored per Madera County Ordinance							
	Any hazardous material or hazardous waste as it relates to the HVAC operations shall be permitted, stored, transported and disposed of in accordance with Federal, State and Local regulations.							
	Applicant shall implement vector and pest control measures to include, but not be limited to, ensure good drainage of manured areas, frequent flusing of lanes, and repair of all leaking pipes and fixtures							
<b>Hydrology and Water Quality</b>								

