

S:\ENG\STANDARD PLANS\County\ST-28 Trench Resurfacing.DWG 2-27-12 01:01:59 PM jchandler

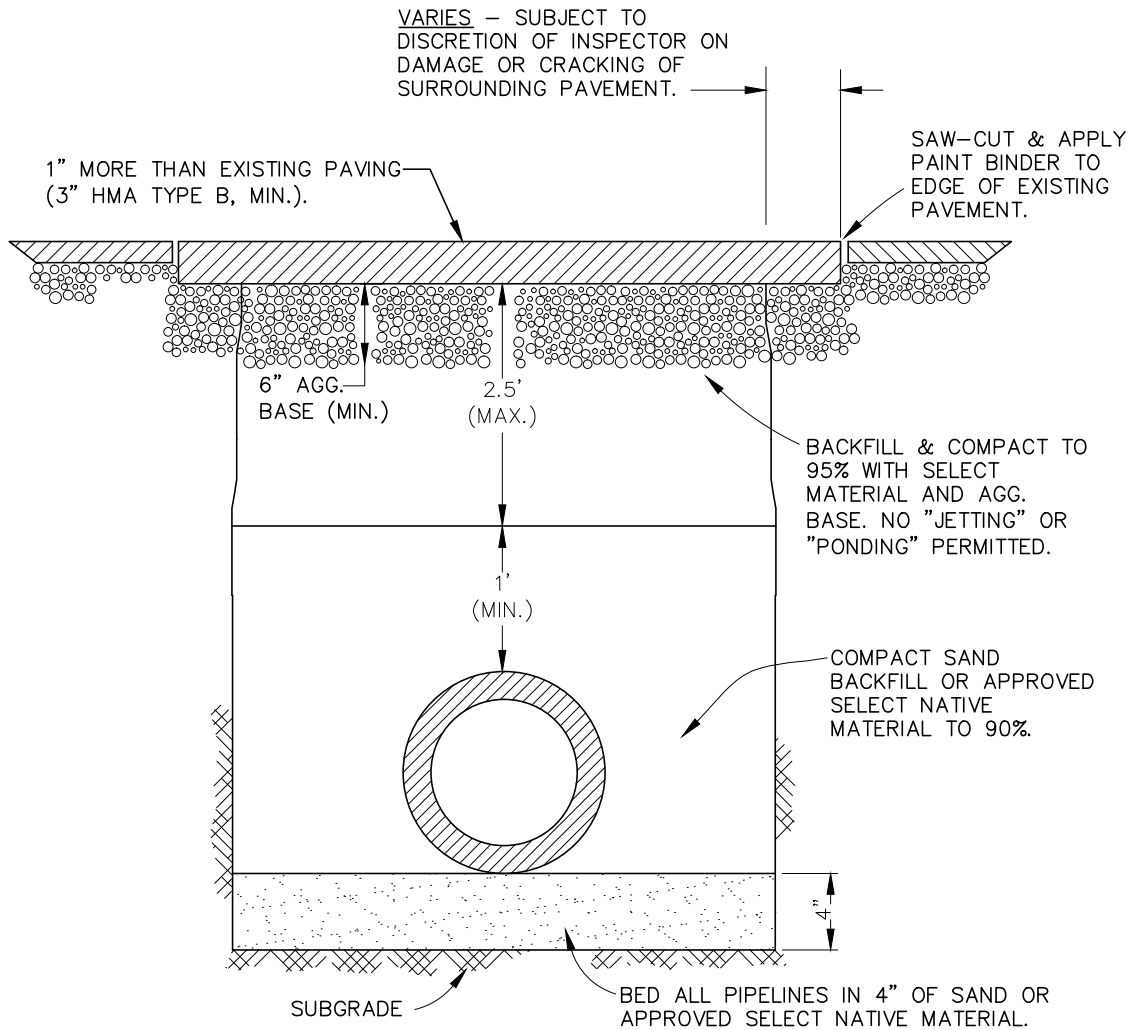

NOTES:

1. SHORING OR TAPERED BANKS WILL BE REQUIRED FOR ANY TRENCH 5' OR MORE IN DEPTH.
2. IN ALL CASES A MINIMUM OF 3" OF PAVING (HOT MIXED ASPHALT) OVER 6" CLASS 2 A.B. OR EQUIVALENT IS REQUIRED. PAVING MATERIAL TO BE THE SAME AS THAT REMOVED. (NEW PAVEMENT TO BE 1" THICKER THAN EXISTING).
3. DECOMPOSED GRANITE MAY NOT BE USED FOR BACK FILL OR PIPE BEDDING.
4. COMPACTION TESTS BY A CERTIFIED LAB WILL BE REQUIRED FOR ALL TRENCH BACKFILL. CONTRACTOR TO BEAR FULL EXPENSE OF ALL TESTING, EXCEPT OTHERWISE SPECIFIED IN THE PROJECT'S SPECIAL PROVISIONS.
5. UPPER LIFT OF NEW HMA PAVEMENT SHALL CONTAIN AGGREGATE OF 1/2" MAXIMUM MEDIUM.
6. A HEATER REMIX PROCESS MAY BE USED IN-LIEU-OF THE "T" SLOT OVERLAY. THE HEATER REMIX PROCESS CALLS FOR THE EDGES OF THE SAWCUT TRENCH LINE TO BE HEATED TO A TEMPERATURE THAT ALLOWS THE EXISTING AC TO BECOME PLIABLE. THE EXISTING AND NEW AC IS THEN SCARIFIED, MIXED TO A HOMOGENOUS MIXTURE AND THEN COMPACTED TO PROVIDE A SEAMLESS JOINT ALONG THE TRENCH EDGES. A REJUVENATING AGENT MAY BE REQUIRED TO RESTORE THE BINDER IN THE EXISTING AC.
7. ALL TRENCH RESURFACINGS SHALL BE FOG SEALED PER CALTRANS STD. SPECIFICATION SECTIONS 37 AND 94 (TABLE 1, GRADE SS1 OR SS1H).

DRAWN BY _____
 DATE 12/24/1981
 REVISED BY J.S.C.
 DATE 3/3/2011

COUNTY OF MADERA
**STREET EXCAVATION, BACKFILL
 & SURFACE RESTORATION**

DRAWING NO.
 ST-28